

F18 & F18-DP Technical Manual

May 2004 Rm



INDEX

PAGE 3	OVER VIEW OF TOP CONTROL PANEL
PAGE 4	DOOR SWITCH 20548
PAGE 5	POWER SWITCH 20044, 20500
PAGE 6	PRESSOSTAT 20058
PAGE 7	WATER LEVEL SYSTEM
PAGE 8	SOLENOID VALVE 20569
PAGE 9	THERMOSTAT, RINSE 20596
PAGE 10	THERMOSTAT, WASH 20570
PAGE 11	CONTACTOR RELAY 20104
PAGE 12	START SWITCH 20519
PAGE 13	START RELAY 20067
PAGE 14	TIMER 20518
PAGE 15	TIMER SEQUENCE
PAGE 16	ELECTRICAL DIAGRAM
PAGE 17	OVERVIEW OF THE BASE
PAGE 18	WASH SYSTEM/PLUMBING
PAGE 19	WASH SYSTEM (cont.)
PAGE 20	WASH PUMP 20240
PAGE 21	DRAIN PUMP 40229
PAGE 22	HEATER ELEMENTS 20080, 20088
PAGE 23	FILL CYCLE AND HEAT CYCLE
PAGE 24	HEAT CYCLE (cont.)
PAGE 25	WASH CYCLE
PAGE 26	WASH CYCLE (cont.)
PAGE 27	DRAIN CYCLE
PAGE 28-31	CHEMICAL PUMP ADJUSTMENT
PAGE 32	ELECTRICAL SCHEMATIC



F-18

1 888 275 4538 - 611
 514 737 9701 - 611
 FAX 514 737 2792



Electrical component location - Top view

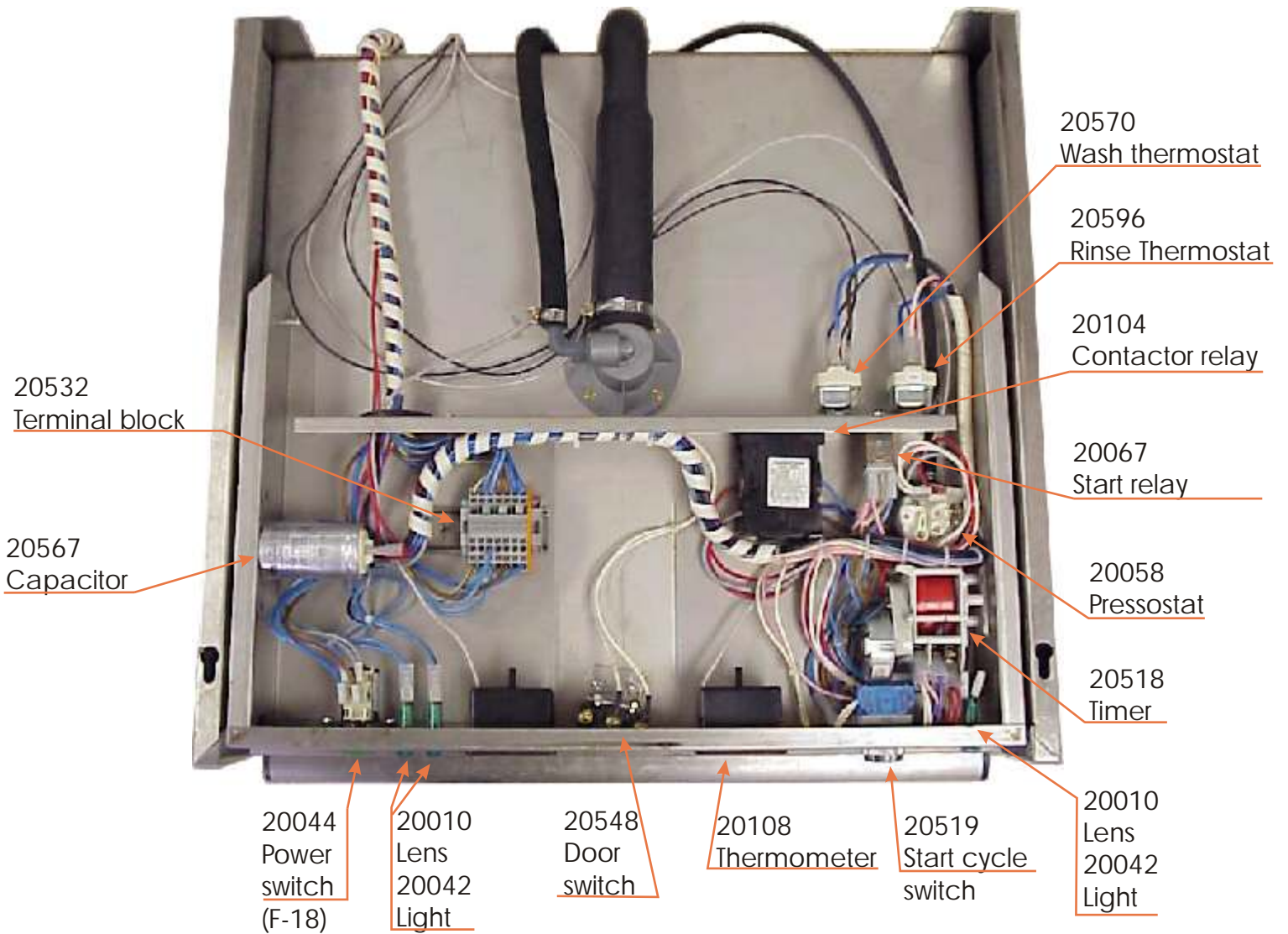

Front of dishwasher

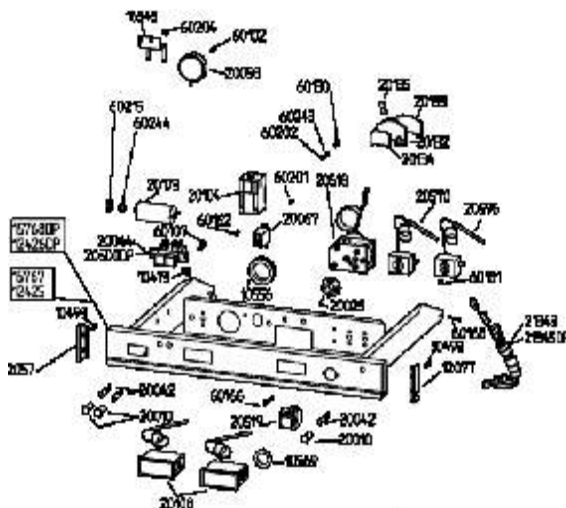

POWER SWITCH

ELECTRICAL DIAGRAM OF F-18 DP DISHWASHER

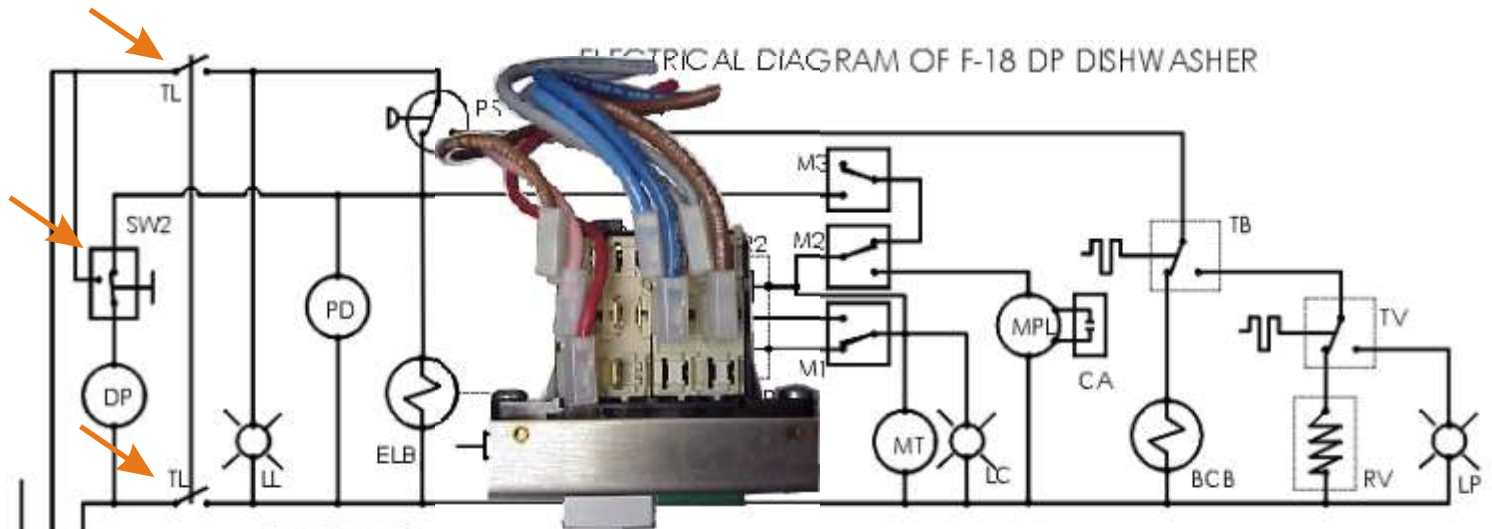

- TL- Power Switch
- PS- Pressure Switch
- SW2- Drain Switch
- CR1 + CR2 - Micro Relay Switches
- M1 + M2 + M3: Timer Cam Switches
- TC- Start Switch
- MP - Door Switch
- TB - Thermostat
- TV - Thermostat
- CCB - Booster Contactor Contacts
- ELB - Solenoid Coil

- PD - Soap Pump
- BR - Micro Relay coil
- BCB - Booster Contactor coil
- RV - Wash Tank Heater Element
- RB - Booster Tank Heater Element
- DP - Drain Pump
- MT - Timer Motor
- MPL - Wash Pump Motor
- LL - Indicator Light - Power
- LC - Indicator Light - Wash Cycle
- LP - Indicator Light - Temperature Ready
- CA - Capacitor - wash pump

Power Button

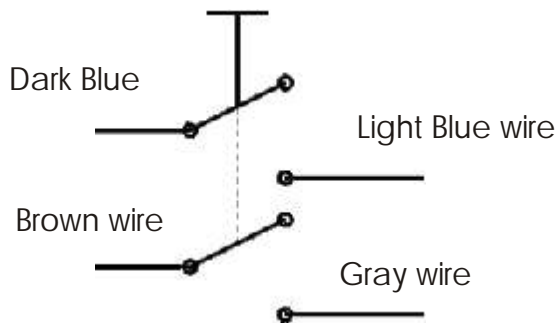

Drain Pump By-pass switch

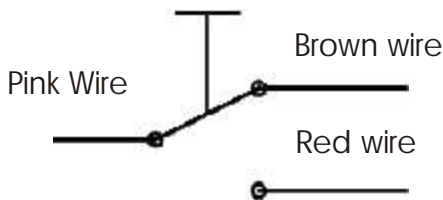

20500
F-18 DP



20044
F-18



Power Switch Location

PRESSOSTAT 20058

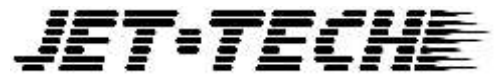

1 888 275 4538 - 611

514 737 9701 - 611

FAX 514 737 2792

ELECTRICAL DIAGRAM OF F-18 DP DISHWASHER

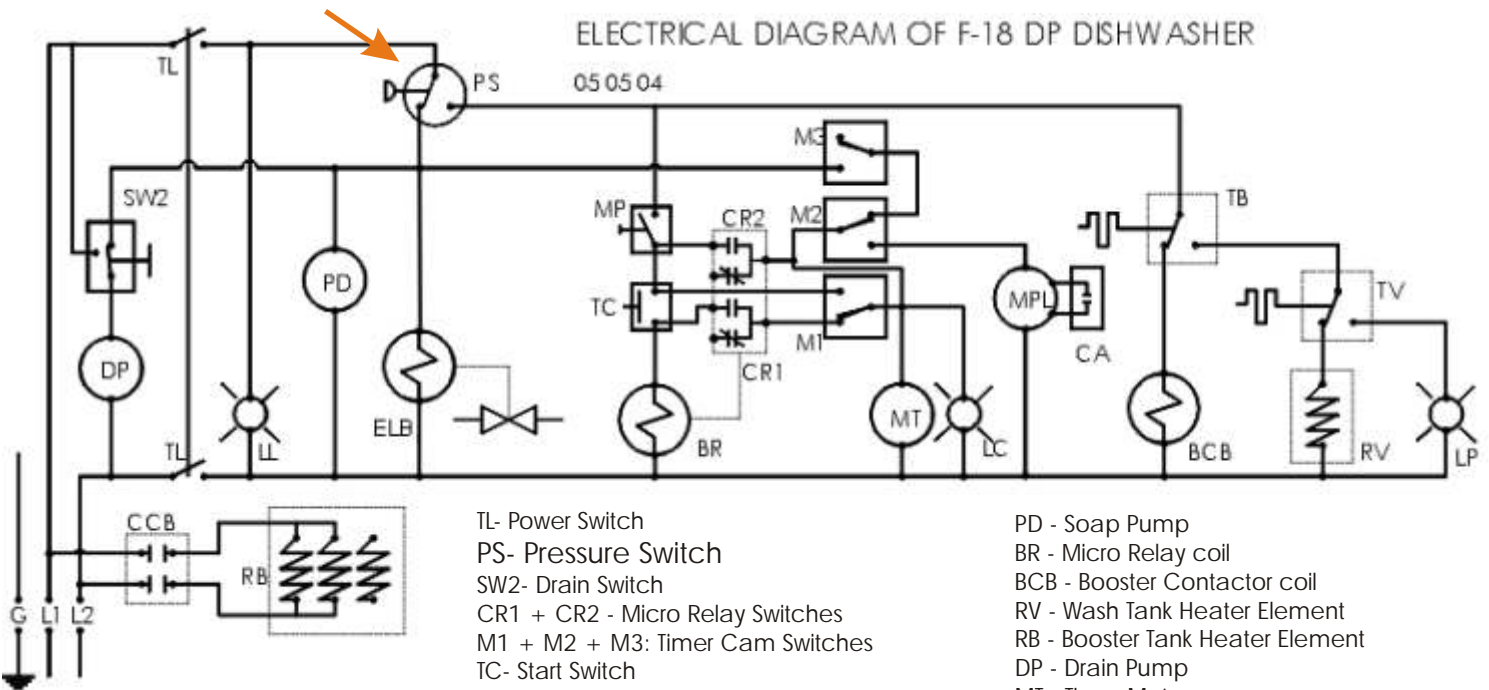

- TL- Power Switch
- PS- Pressure Switch
- SW2- Drain Switch
- CR1 + CR2 - Micro Relay Switches
- M1 + M2 + M3: Timer Cam Switches
- TC- Start Switch
- MP - Door Switch
- TB - Thermostat
- TV - Thermostat
- CCB - Booster Contactor Contacts
- ELB - Solenoid Coil

- PD - Soap Pump
- BR - Micro Relay coil
- BCB - Booster Contactor coil
- RV - Wash Tank Heater Element
- RB - Booster Tank Heater Element
- DP - Drain Pump
- MT - Timer Motor
- MPL - Wash Pump Motor
- LL - Indicator Light - Power
- LC - Indicator Light - Wash Cycle
- LP - Indicator Light - Temperature Ready
- CA - Capacitor - wash pump



Back of dishwasher



Pressostat Location

Water Level System

The dishwasher water level is control by a pressure switch or pressostat. A cup (grey plastic cylinder, #10528) located at the back of the unit will keep an air pocket which will be pressurized as the water level increases. The air pressure (approximately 2 inch water column) activates a switch through a rubber tube that connects from the air trap to the pressostat.

During the fill cycle, the water solenoid gets its signal from the pressostat. When the pressostat is satisfied, it cuts the signal to the solenoid valve and sends power to the thermostats and the timer

When trouble shooting this system, all components must be considered.

Beginning with the pressostat which is adjustable.

Making sure the connection to the tube is air tight.

The tube may have an invisible crack which allows air to escape.

The air trap may be broken or the threads may have a crack also.

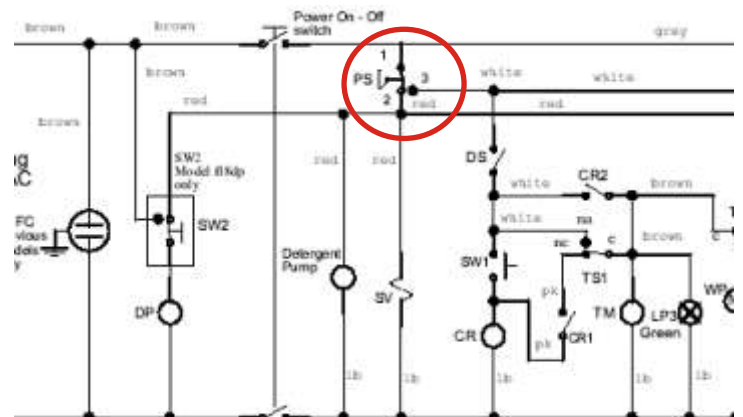
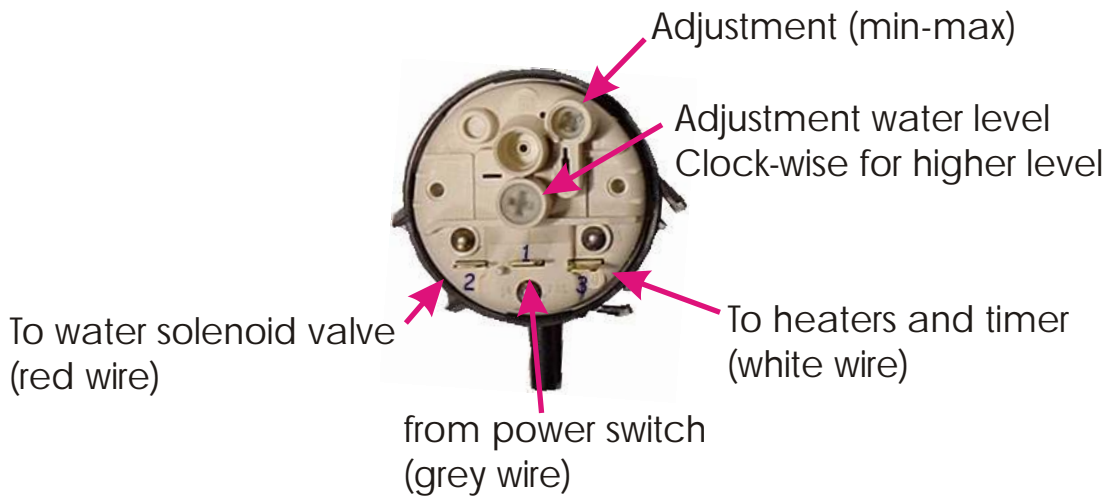
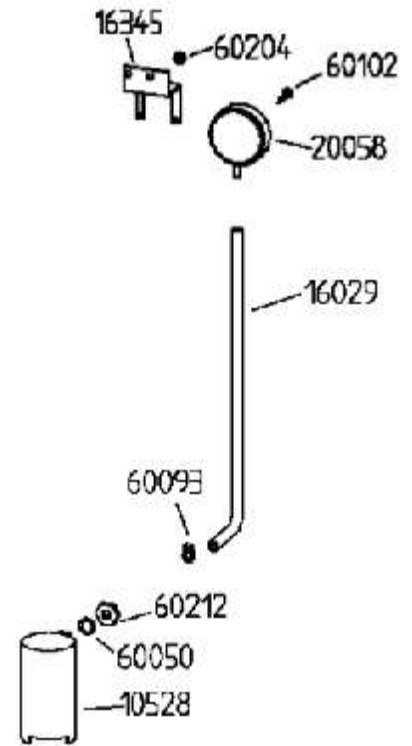

Fill System & Rinse System



The dishwasher fill and rinse systems is practically the same system as they both used the same circuit. The only difference is what is sending the signal to the water solenoid valve.

During the fill cycle, the water solenoid gets its signal from the pressostat. When the pressostat is satisfied, it cuts the signal to the solenoid valve and sends power to the thermostats and the timer.

During the Rinse cycle, the water solenoid valve is getting its signal from the timer. When the time has completed the rinse cycle than the solenoid is de-energized.

Because the detergent pump and the drain pump (if so equipped) are connected in parallel with the water solenoid valve, they will all work at the same time. Why are they connected this way? Simple, the detergent pump is connected this to inject detergent whenever new water comes into the dishwasher. The detergent does not mix with the rinse system so it does not contaminate the rinsing process with detergent.

The drain pump will work whenever the water solenoid opens and this is to avoid overflow problem should the pressostat becomes defective and the unit get stuck in a fill cycle. Here it si important to keep in mind that this scenario will only work if the dynamic (flow) water pressure does not exceed 25 PSI and the unit is capable of totally draining within 1 minute. If any of those two factors exceeds the limits then you can have an overflow situation.

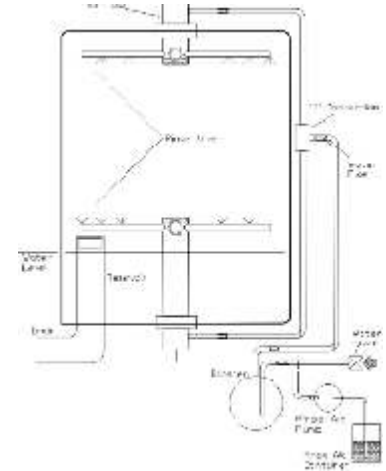
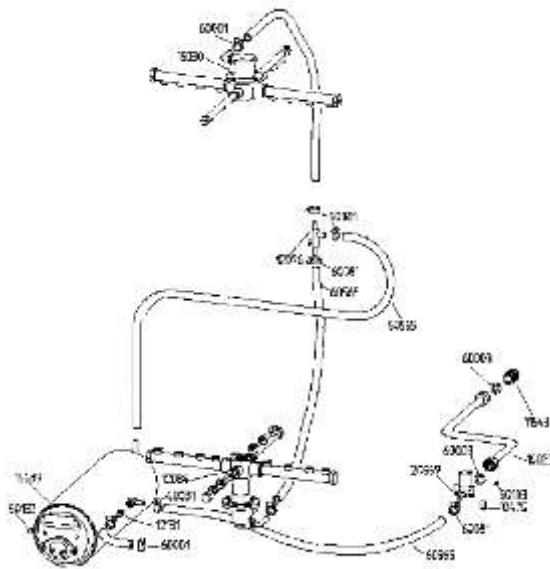

The water solenoid valve will send water through the booster first and then water will travel to the spray-arms as shown in the diagram below. The solenoid valve will fail under specific condition. High pressure(>2.0 bar: >30 PSI) , high temperature(>60C:>140F), debris in water, continuous work.

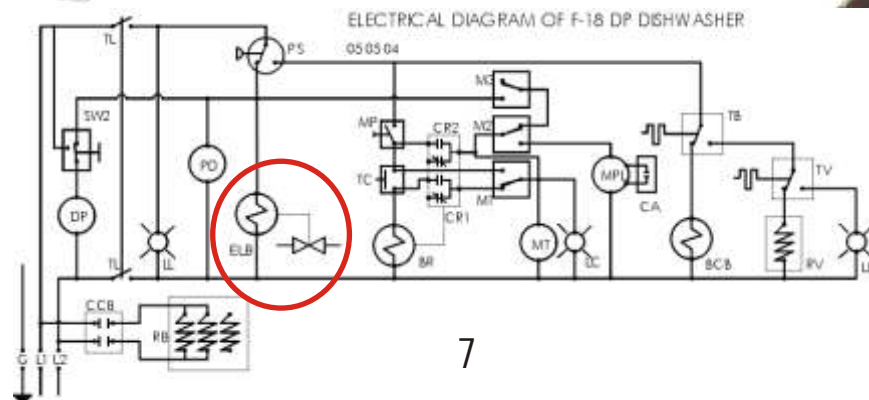

THERMOSTAT 20596

1 888 275 4538 - 611
 514 737 9701 - 611
 FAX 514 737 2792

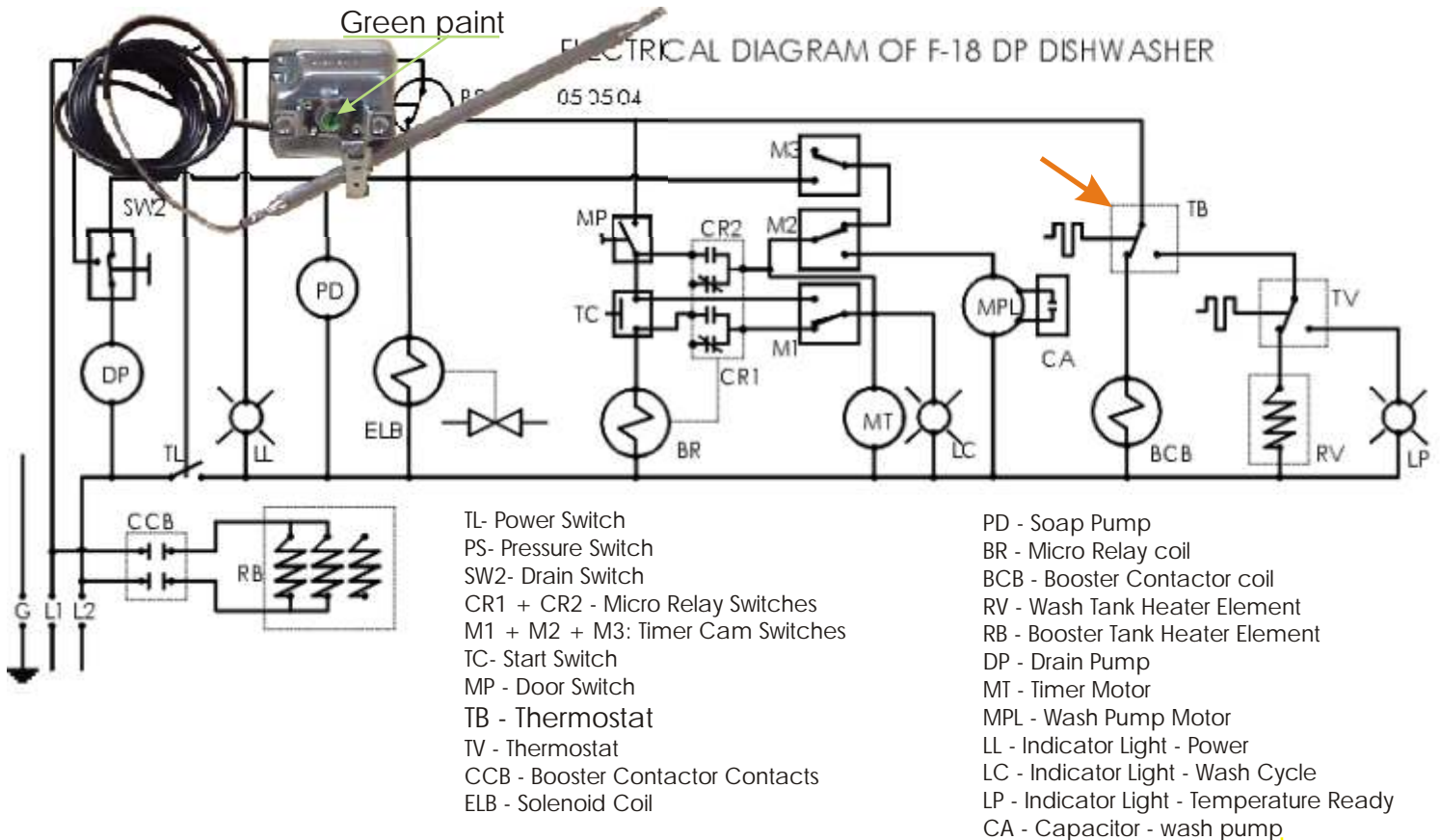

190F +/- 2

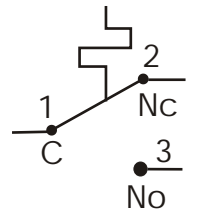

From pressostat (white)

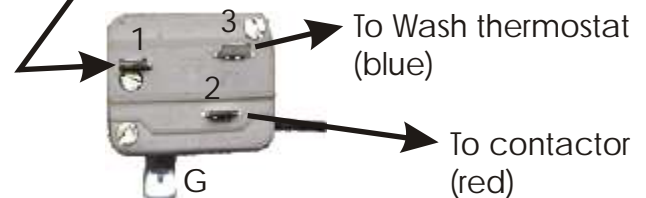

THERMOSTAT 20570

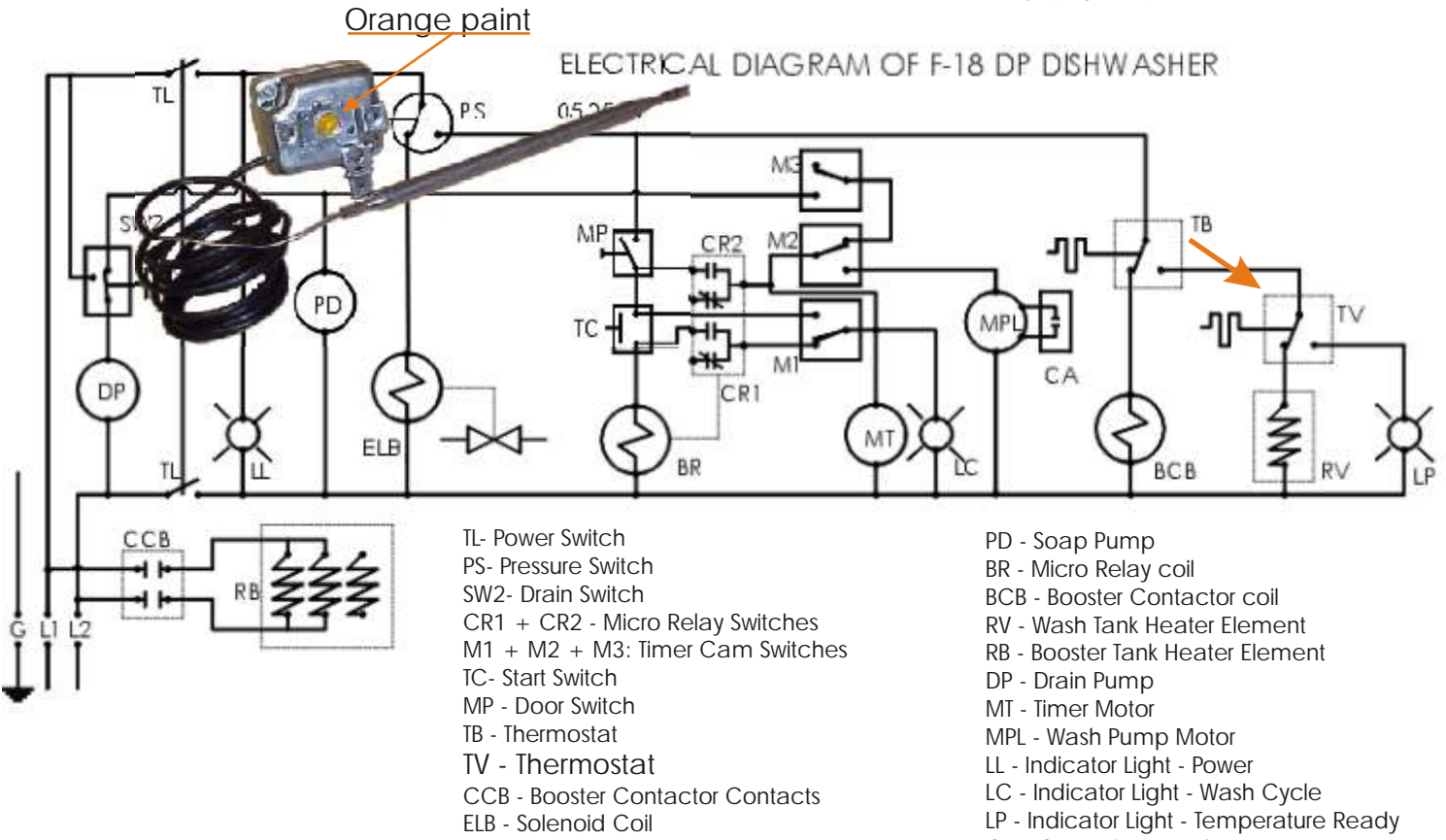

160F +/- 2

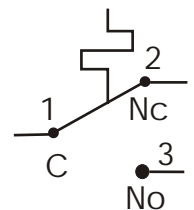

From rinse thermostat (blue)

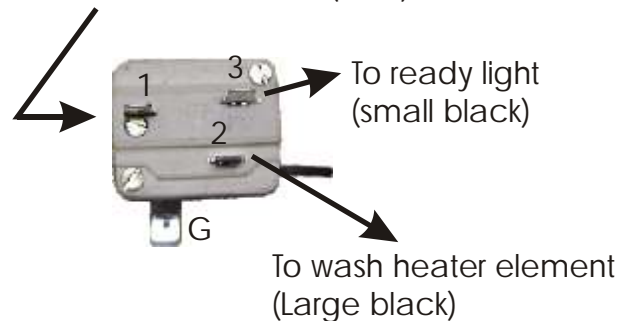

CONTACTOR RELAY 20104

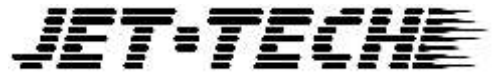

1 888 275 4538 - 611
 514 737 9701 - 611
 FAX 514 737 2792

ELECTRICAL DIAGRAM OF F-18 DP DISHWASHER

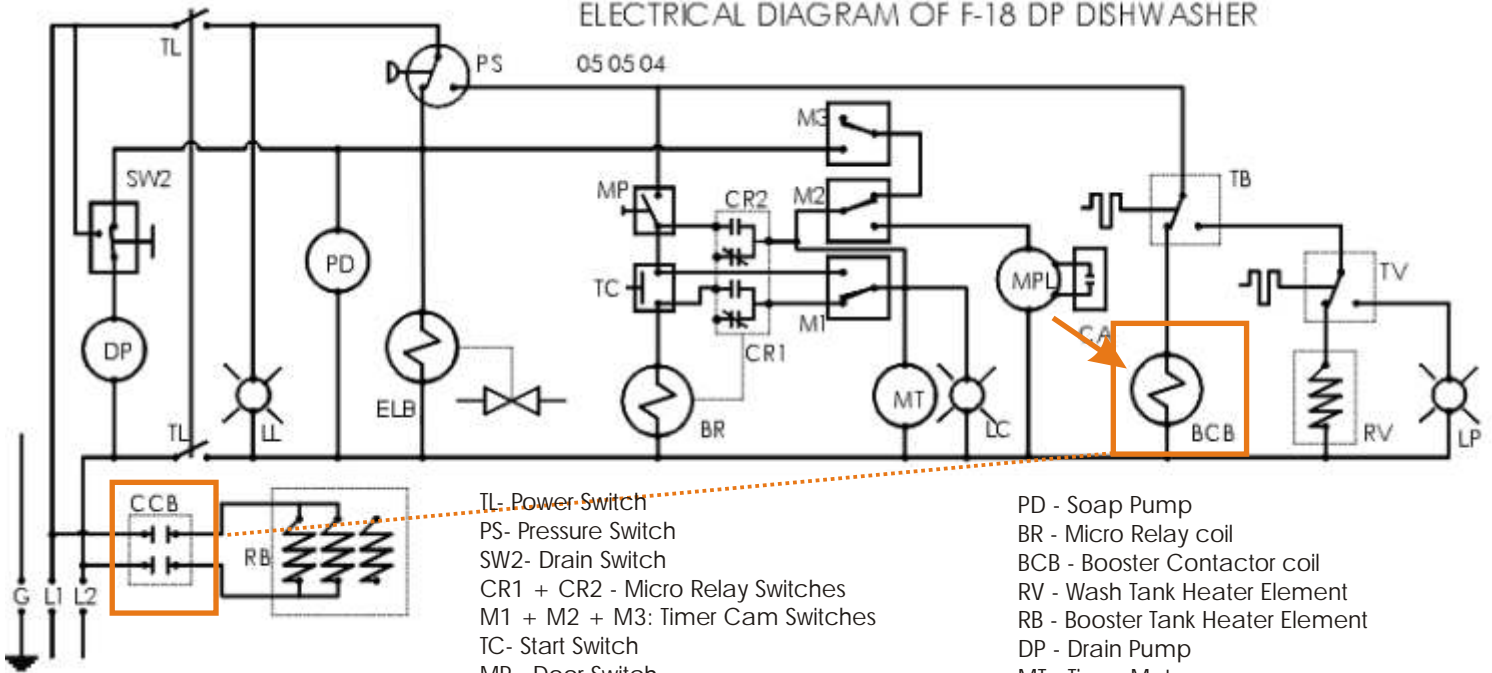

- TL- Power-Switch
- PS- Pressure Switch
- SW2- Drain Switch
- CR1 + CR2 - Micro Relay Switches
- M1 + M2 + M3: Timer Cam Switches
- TC- Start Switch
- MP - Door Switch
- TB - Thermostat
- TV - Thermostat
- CCB - Booster Contactor Contacts
- ELB - Solenoid Coil

- PD - Soap Pump
- BR - Micro Relay coil
- BCB - Booster Contactor coil
- RV - Wash Tank Heater Element
- RB - Booster Tank Heater Element
- DP - Drain Pump
- MT - Timer Motor
- MPL - Wash Pump Motor
- LL - Indicator Light - Power
- LC - Indicator Light - Wash Cycle
- LP - Indicator Light - Temperature Ready
- CA - Capacitor - wash pump

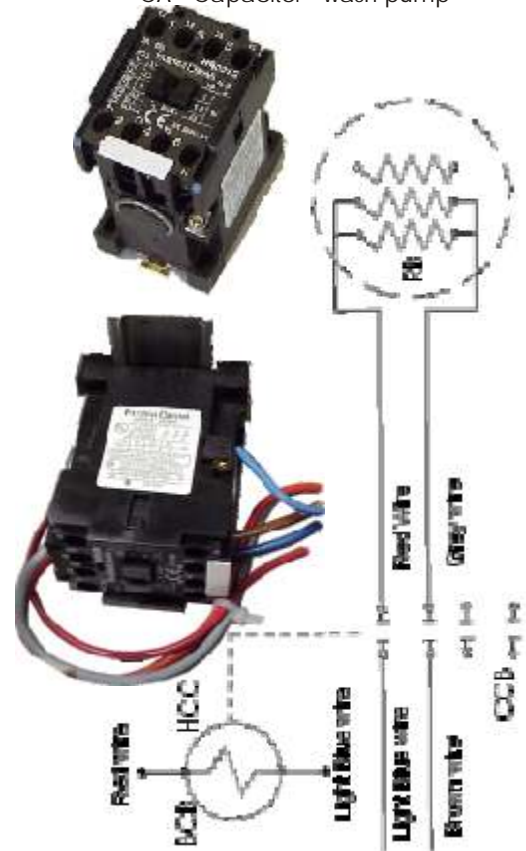

DOOR SWITCH 20548

1 888 275 4538 - 611
 514 737 9701 - 611
 FAX 514 737 2792

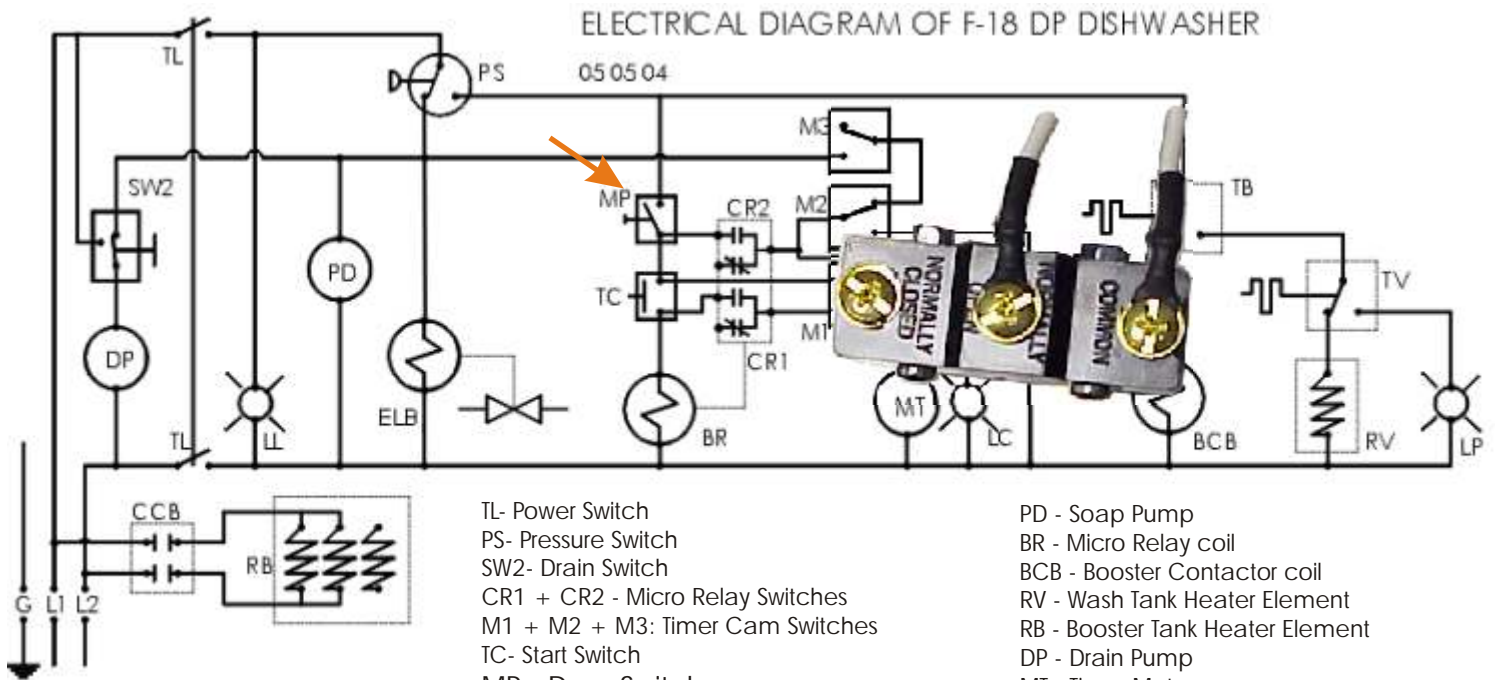

- TL- Power Switch
- PS- Pressure Switch
- SW2- Drain Switch
- CR1 + CR2 - Micro Relay Switches
- M1 + M2 + M3: Timer Cam Switches
- TC- Start Switch
- MP - Door Switch
- TB - Thermostat
- TV - Thermostat
- CCB - Booster Contactor Contacts
- ELB - Solenoid Coil

- PD - Soap Pump
- BR - Micro Relay coil
- BCB - Booster Contactor coil
- RV - Wash Tank Heater Element
- RB - Booster Tank Heater Element
- DP - Drain Pump
- MT - Timer Motor
- MPL - Wash Pump Motor
- LL - Indicator Light - Power
- LC - Indicator Light - Wash Cycle
- LP - Indicator Light - Temperature Ready
- CA - Capacitor - wash pump

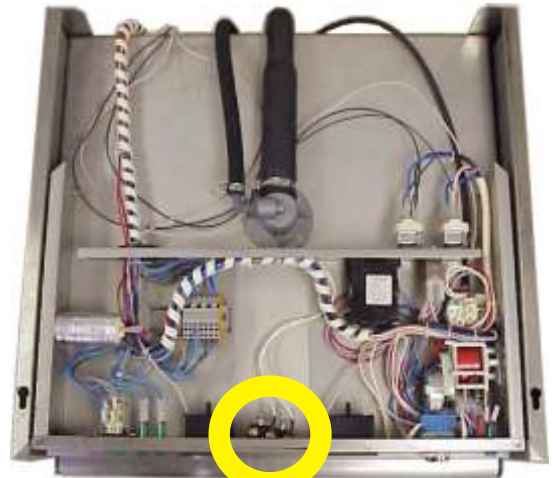
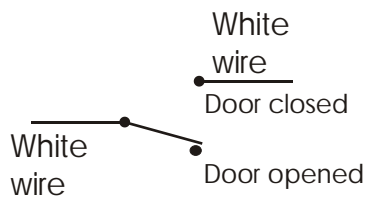
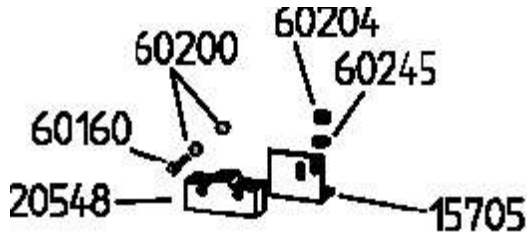

Switch Location

Start Switch 20519

ELECTRICAL DIAGRAM OF F-18 DP DISHWASHER

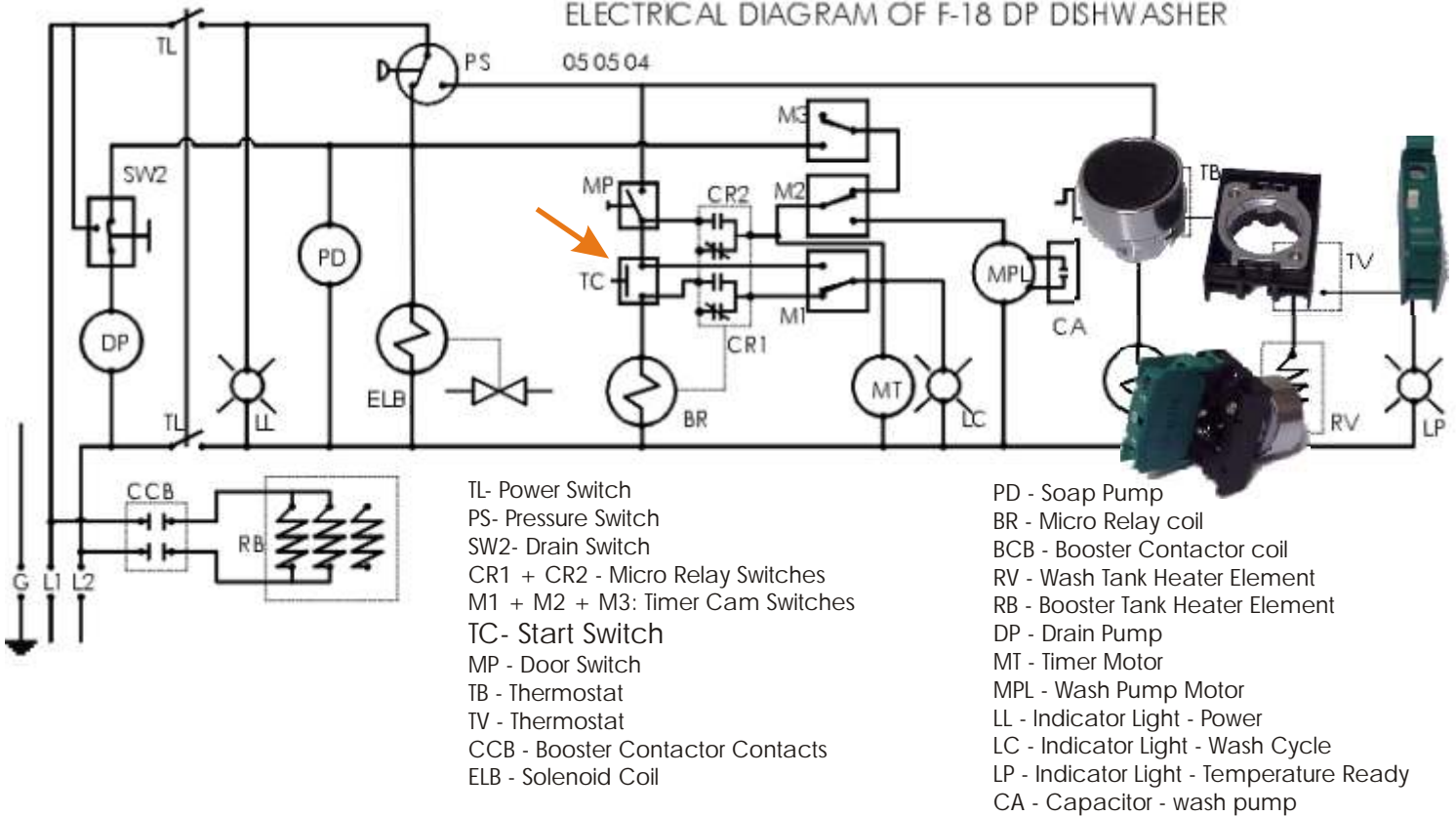

Function of the 20519 Start Switch

This switch, when pushed in, will start the wash and rinse cycle. When the Start Cycle SW1 (20519) button is depressed. The small contactor relay is energized and closes contacts CR1 and CR2. This has two purposes. The first one is to energize both the timer motor and the indicator light LP3 (20042). The second purpose is for CR2 to bypass the Start Switch SW1.

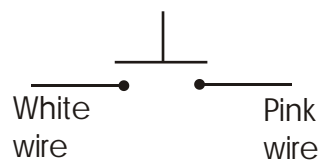
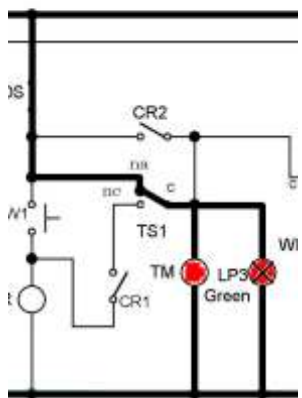
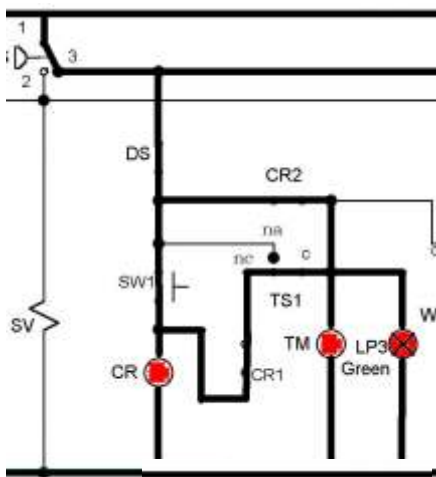

Switch Location

RELAY 20067

ELECTRICAL DIAGRAM OF F-18 DP DISHWASHER

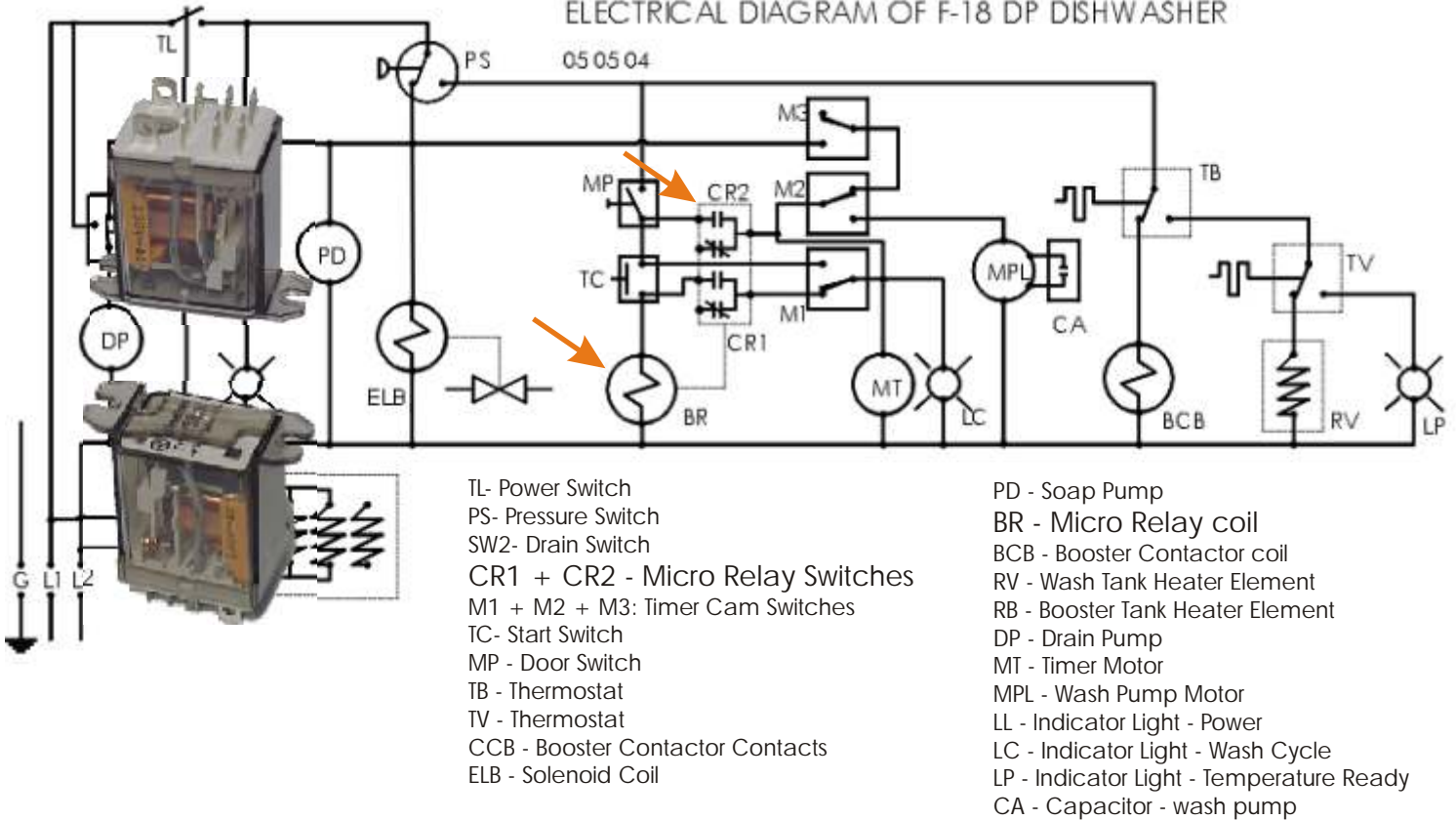

Function of the 20067 relay

This relay once activated by the start-switch signal is design to hold the current until the first cam of the timer hits the micro switch on the timer. At that moment the signal on the relay is disengaged and the timer takes over the start of the wash cycle.

If this part fails, the start switch must be pressed and held for 15 seconds in order to start the wash cycle.

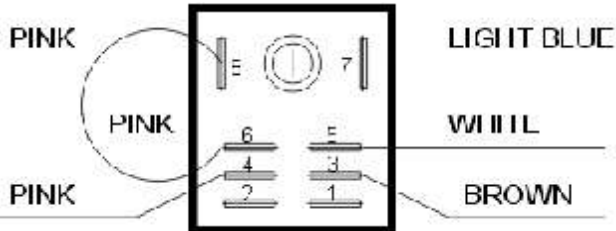

Relay Location

TIMER 20518

1 888 275 4538 - 611
 514 737 9701 - 611
 FAX 514 737 2792

ELECTRICAL DIAGRAM OF F-18 DP DISHWASHER

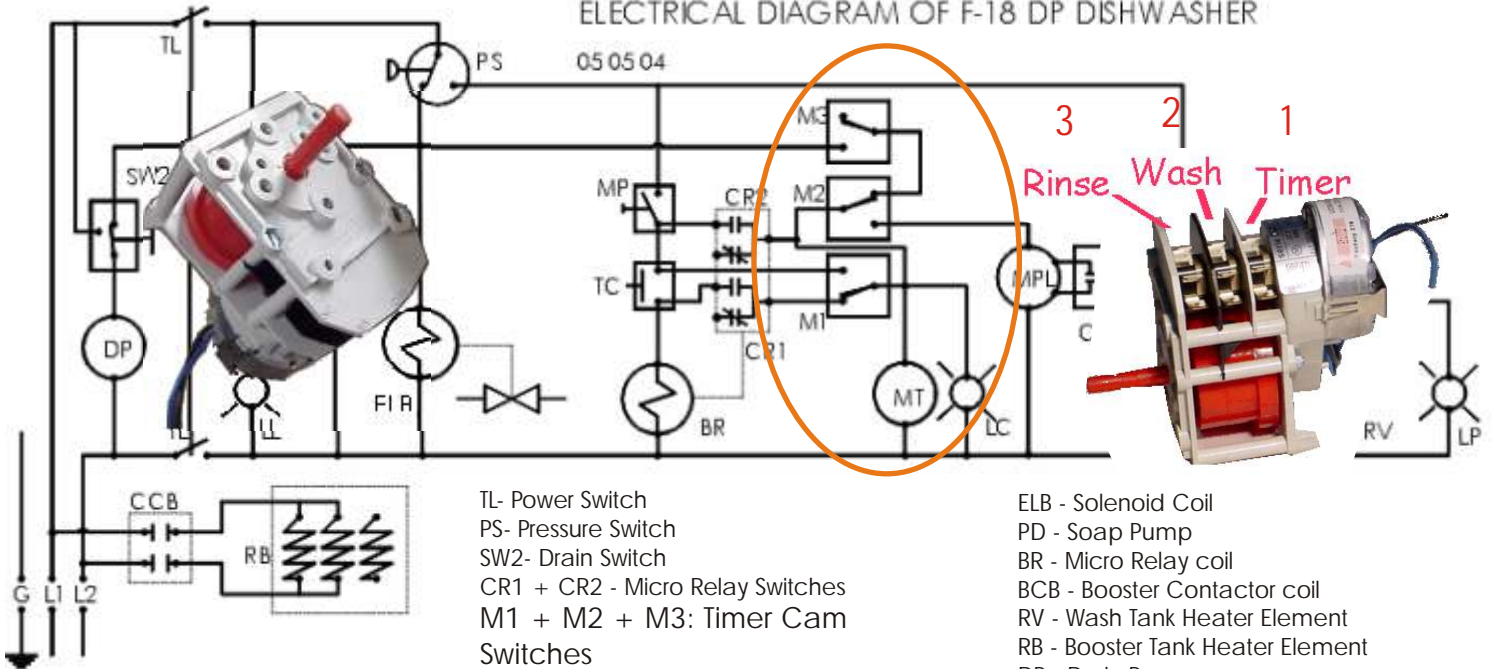

- TL- Power Switch
- PS- Pressure Switch
- SW2- Drain Switch
- CR1 + CR2 - Micro Relay Switches
- M1 + M2 + M3: Timer Cam Switches
- TC- Start Switch
- MP - Door Switch
- TB - Thermostat
- TV - Thermostat
- CCB - Booster Contactor Contacts

- ELB - Solenoid Coil
- PD - Soap Pump
- BR - Micro Relay coil
- BCB - Booster Contactor coil
- RV - Wash Tank Heater Element
- RB - Booster Tank Heater Element
- DP - Drain Pump
- MT - Timer Motor
- MPL - Wash Pump Motor
- LL - Indicator Light - Power
- LC - Indicator Light - Wash Cycle
- LP - Indicator Light - Temperature Ready

TIMER PROGRAM 20518

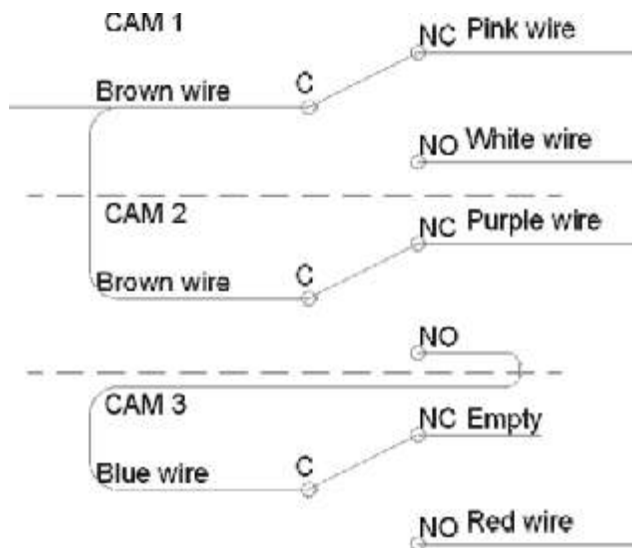
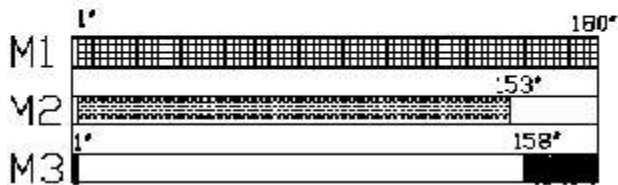

Timer Location

TIMER 20518

TIMER SEQUENCE

1- When the Start Cycle TC (20519) button is depressed. The small contactor relay is energized and closes contacts CR1 (20067) and CR2 (20067). This has two purposes. The first one is to energize both the timer motor and the indicator light LC (20042). The second purpose is for CR2 to bypass the Start Switch TC.

2- The timer motor is energized and starts to turn and closes the first contact M1 (20518) which will bypass the small relay contactor and keep the timer motor running during the entire cycle.

3- As the timer cam continues to turn, the second switch M2 (20518) is closed and energizes the wash pump motor.

4- After 150 seconds approximately, switch M2 opens and switch M3 (20518) closes to energize the solenoid valve (for rinsing), the drain pump and the detergent pump. This function lasts about 20 seconds and the circuit reverts to the beginning.

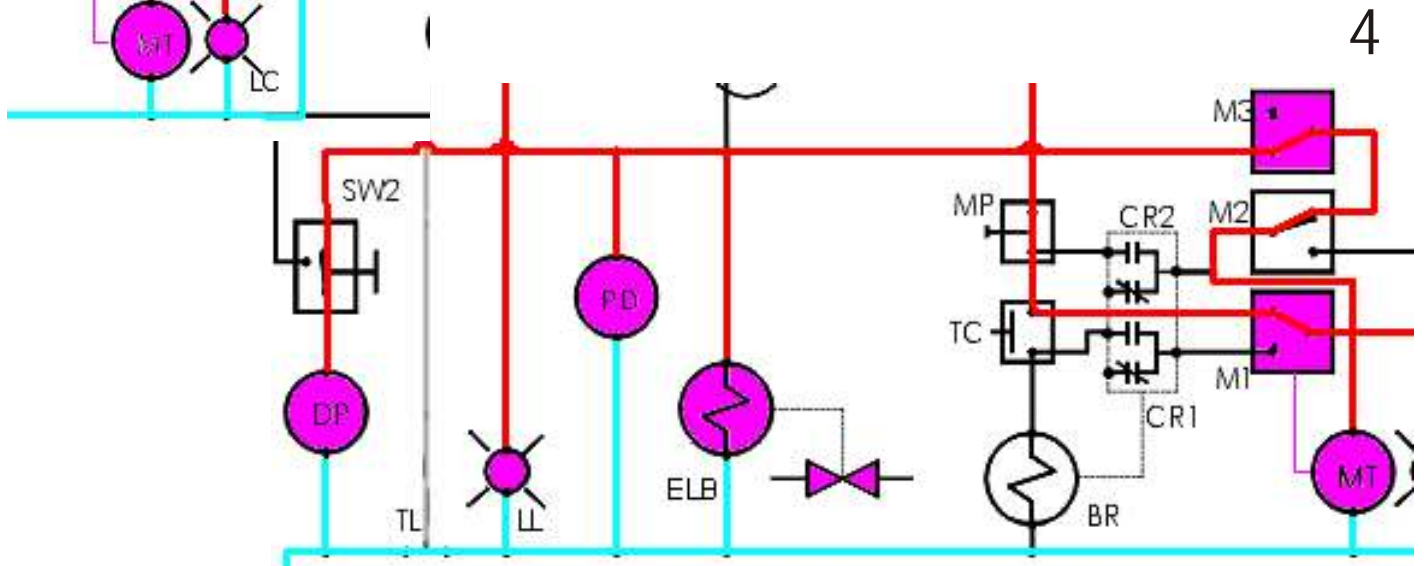
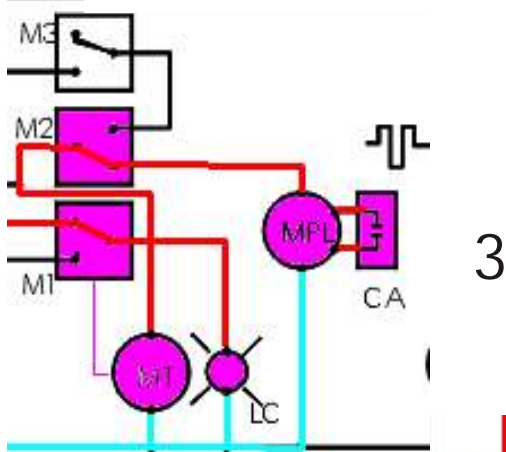
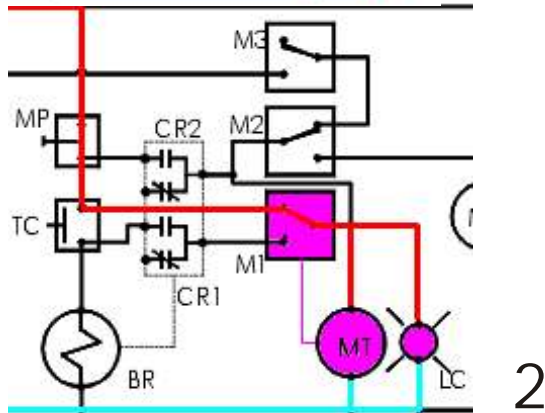
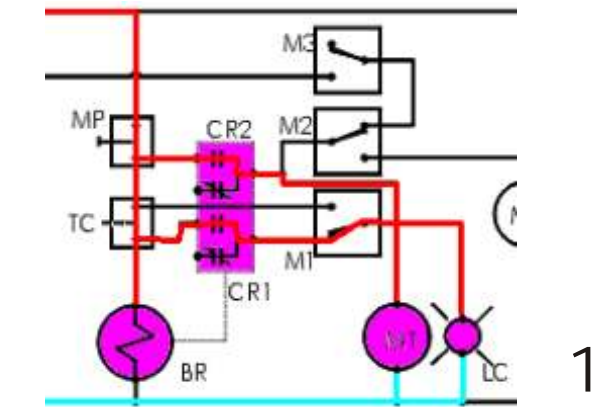

WASH SYSTEM

ELECTRICAL DIAGRAM OF F-18 DP DISHWASHER

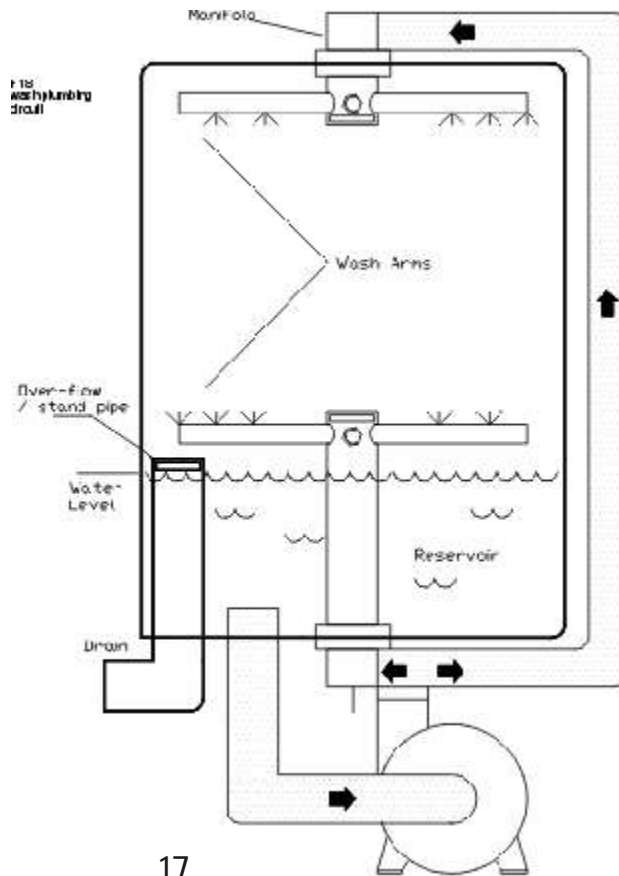
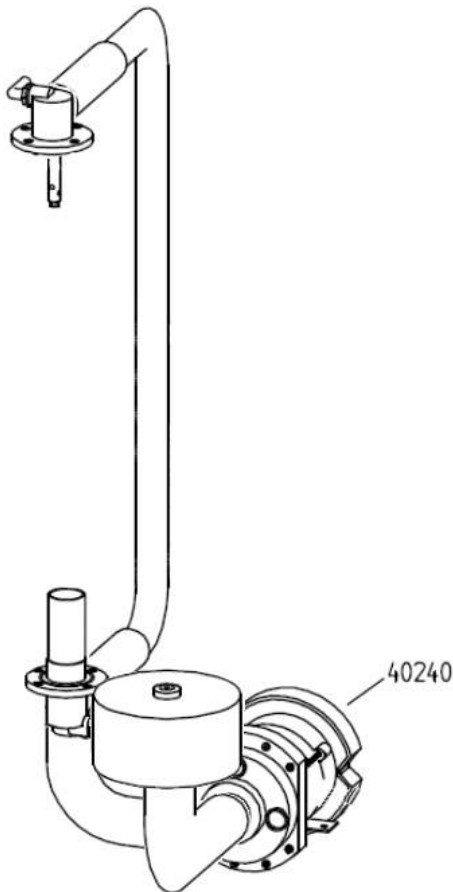
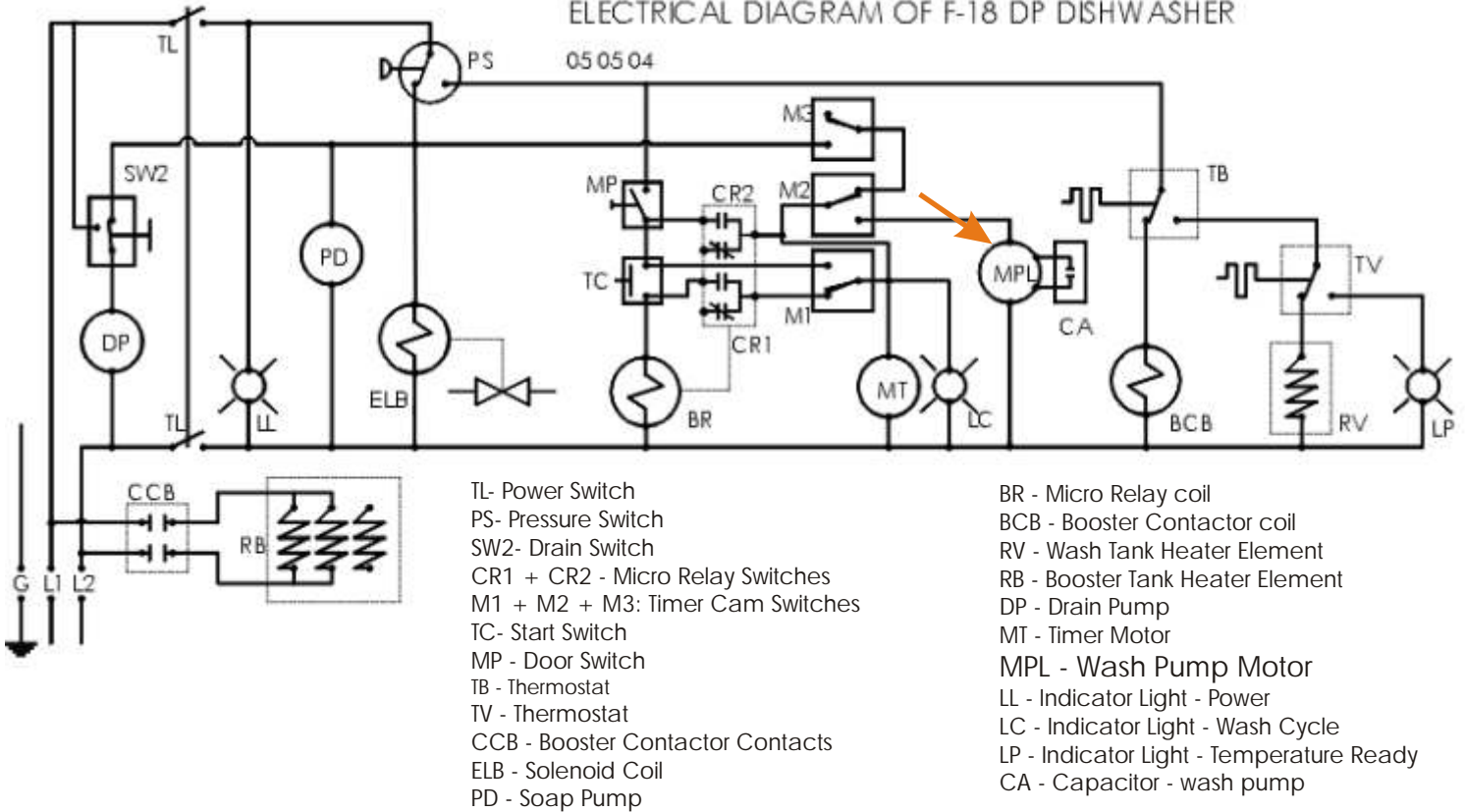

WASH SYSTEM

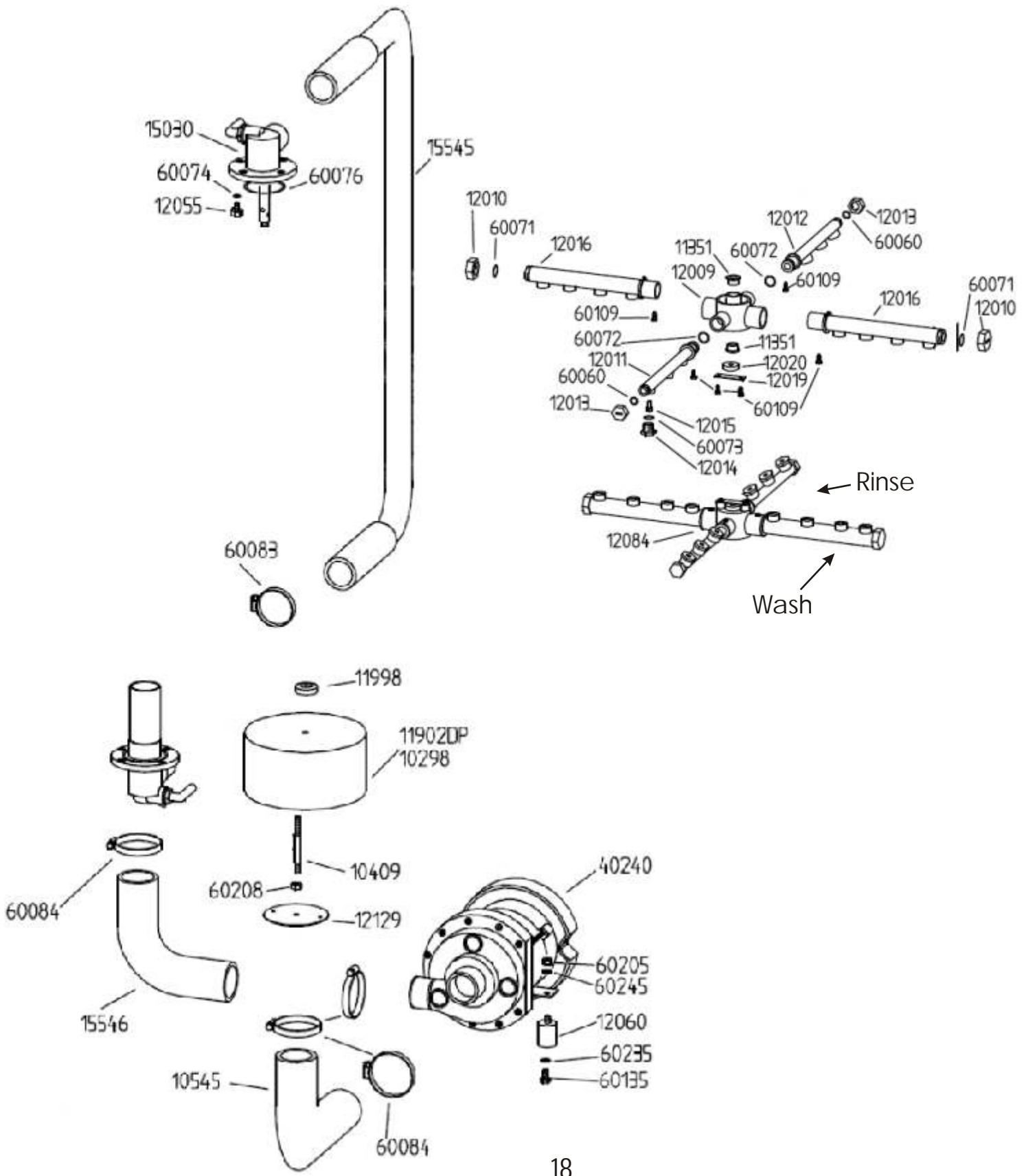

WASH SYSTEM

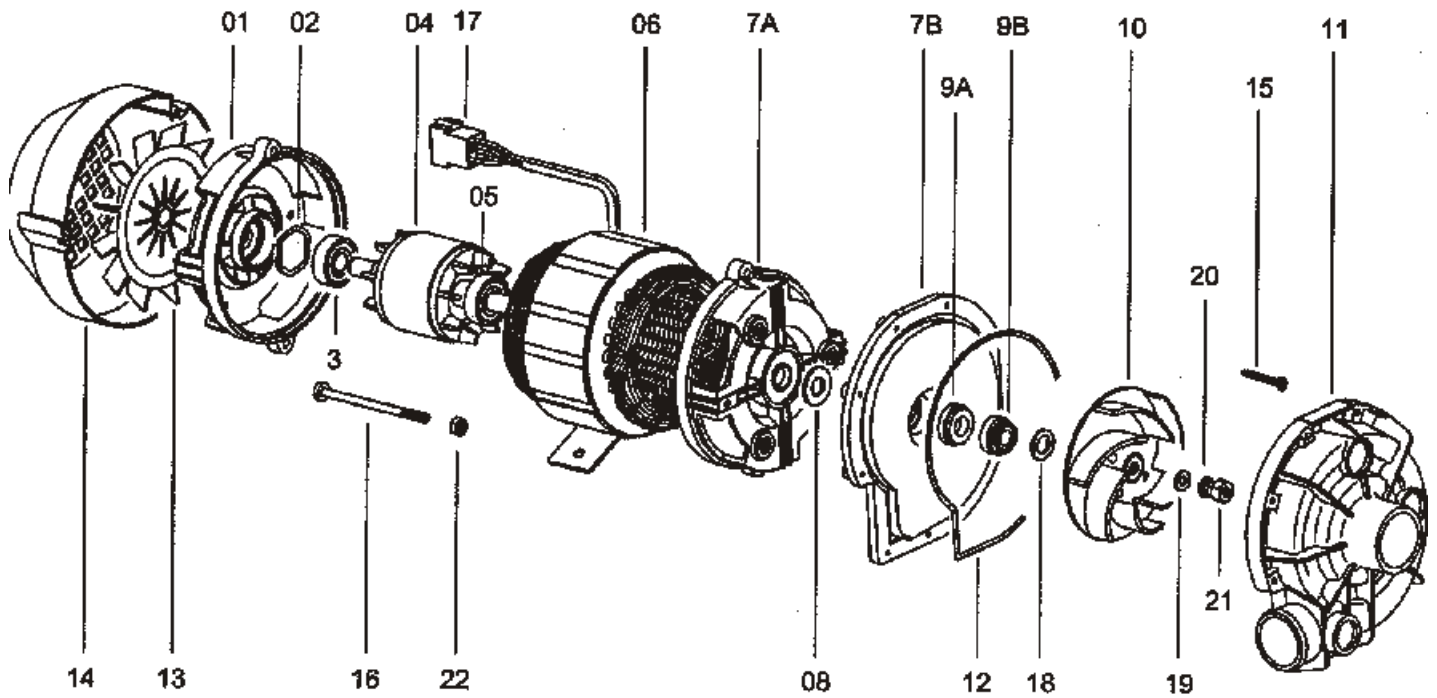

WASH PUMP	...	40240
9A-9BMECHANICAL SEAL	40030
7A-7BPUMP BOTTOM HOUSING	40218
11 PUMP HOUSING	40083
10 IMPELLER	40269
12 GASKET	40113



DRAIN PUMP 40229

ELECTRICAL DIAGRAM OF F-18 DP DISHWASHER

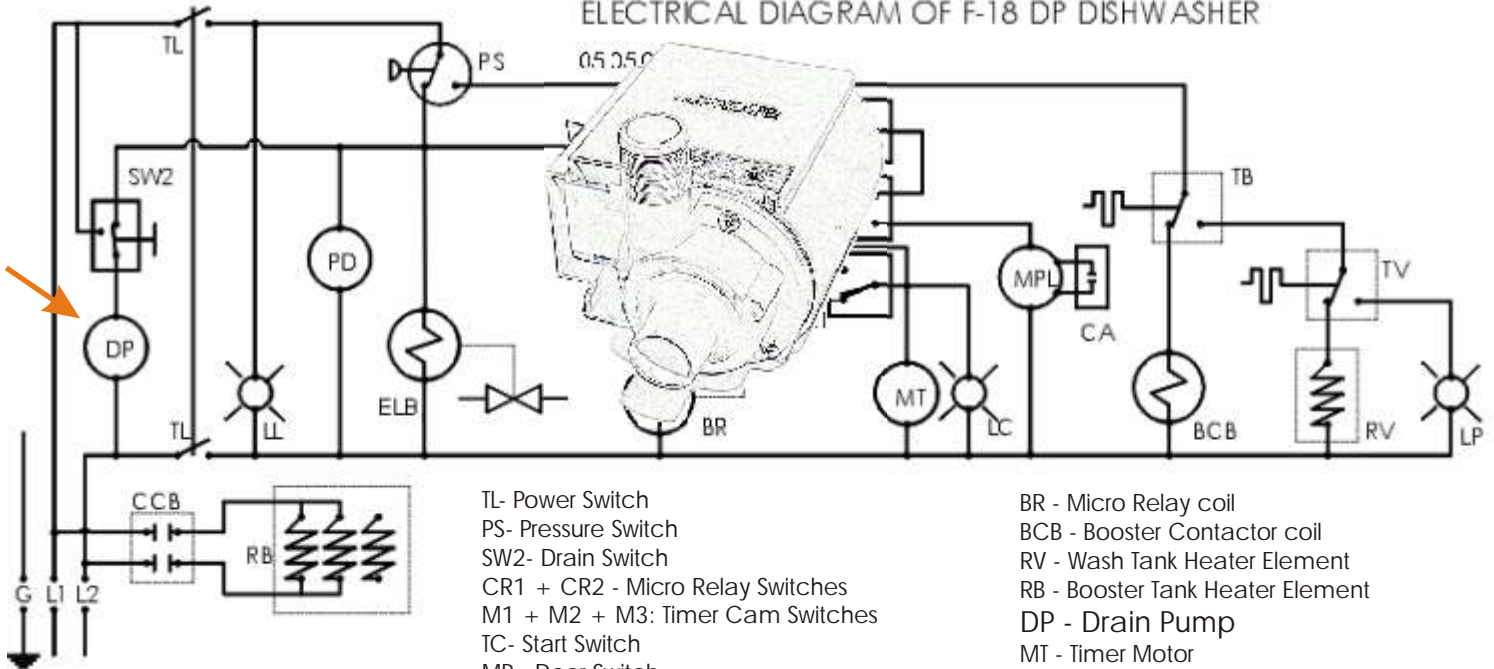

- TL- Power Switch
- PS- Pressure Switch
- SW2- Drain Switch
- CR1 + CR2 - Micro Relay Switches
- M1 + M2 + M3: Timer Cam Switches
- TC- Start Switch
- MP - Door Switch
- TB - Thermostat
- TV - Thermostat
- CCB - Booster Contactor Contacts
- ELB - Solenoid Coil
- PD - Soap Pump

- BR - Micro Relay coil
- BCB - Booster Contactor coil
- RV - Wash Tank Heater Element
- RB - Booster Tank Heater Element
- DP - Drain Pump
- MT - Timer Motor
- MPL - Wash Pump Motor
- LL - Indicator Light - Power
- LC - Indicator Light - Wash Cycle
- LP - Indicator Light - Temperature Ready
- CA - Capacitor - wash pump



40128



40115



40127



40129

Drain opening in wash tank

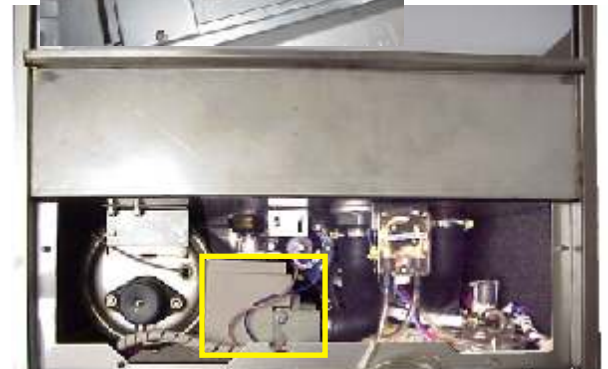
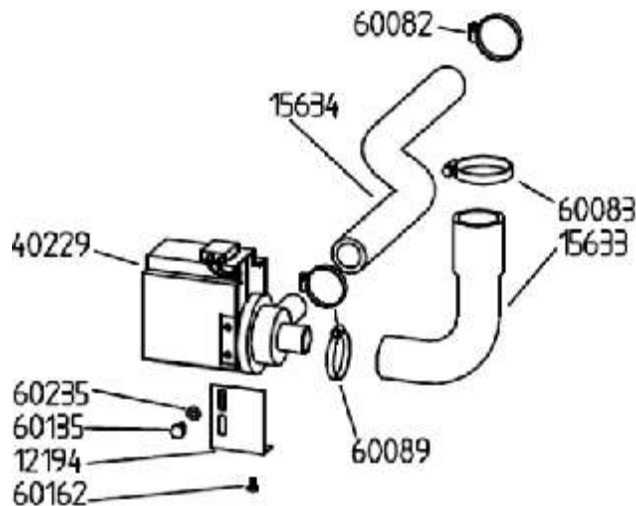

20

Drain Pump Location

F18 Booster

Do not connect

Do not connect

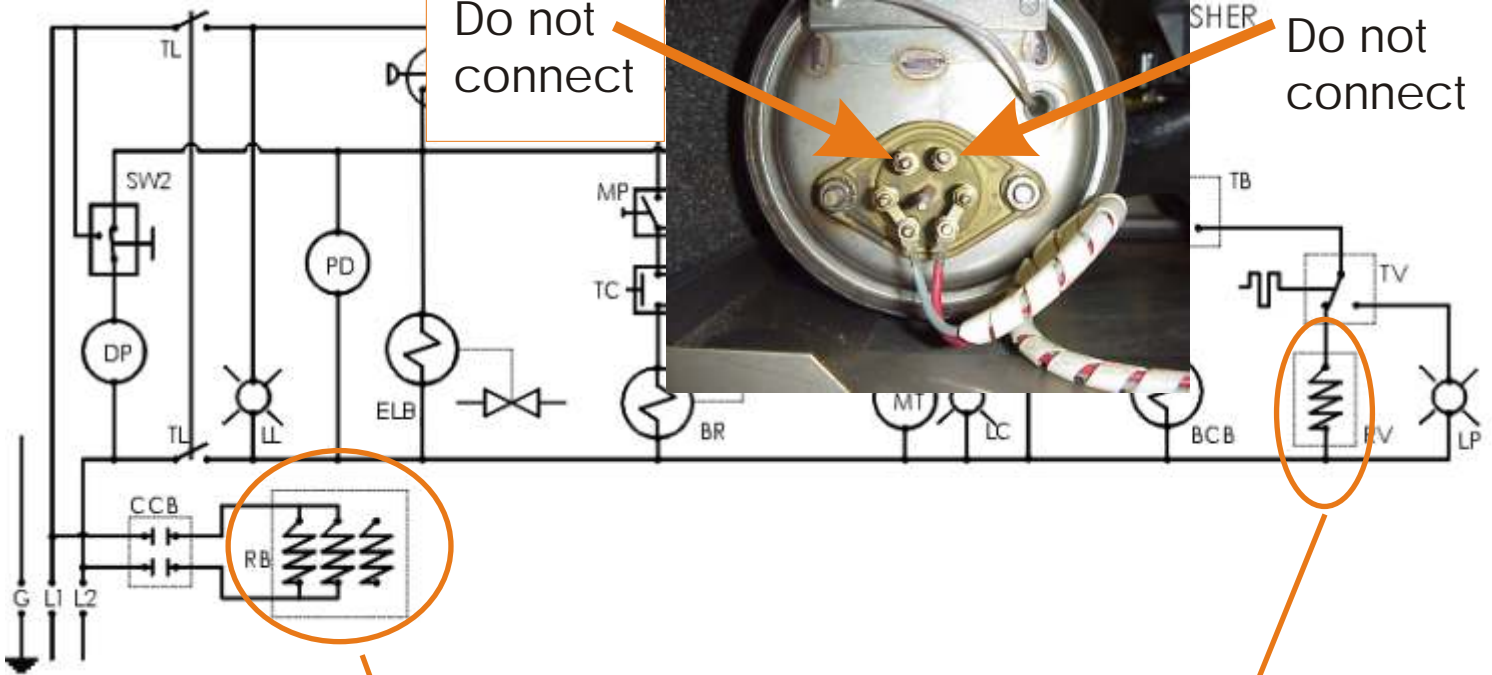

- TL- Power Switch
- PS- Pressure Switch
- SW2- Drain Switch
- CR1 + CR2 - Micro Relay Switches
- M1 + M2 + M3: Timer Cam Switches
- TC- Start Switch
- MP - Door Switch
- TB - Thermostat
- TV - Thermostat
- CCB - Booster Contactor Contacts
- ELB - Solenoid Coil
- PD - Soap Pump
- BR - Micro Relay coil
- BCB - Booster Contactor coil
- RV - Wash Tank Heater Element
- RB - Booster Tank Heater Element
- DP - Drain Pump
- MT - Timer Motor
- MPL - Wash Pump Motor
- LL - Indicator Light - Power
- LC - Indicator Light - Wash Cycle
- LP - Indicator Light - Temperature Ready
- CA - Capacitor - wash pump

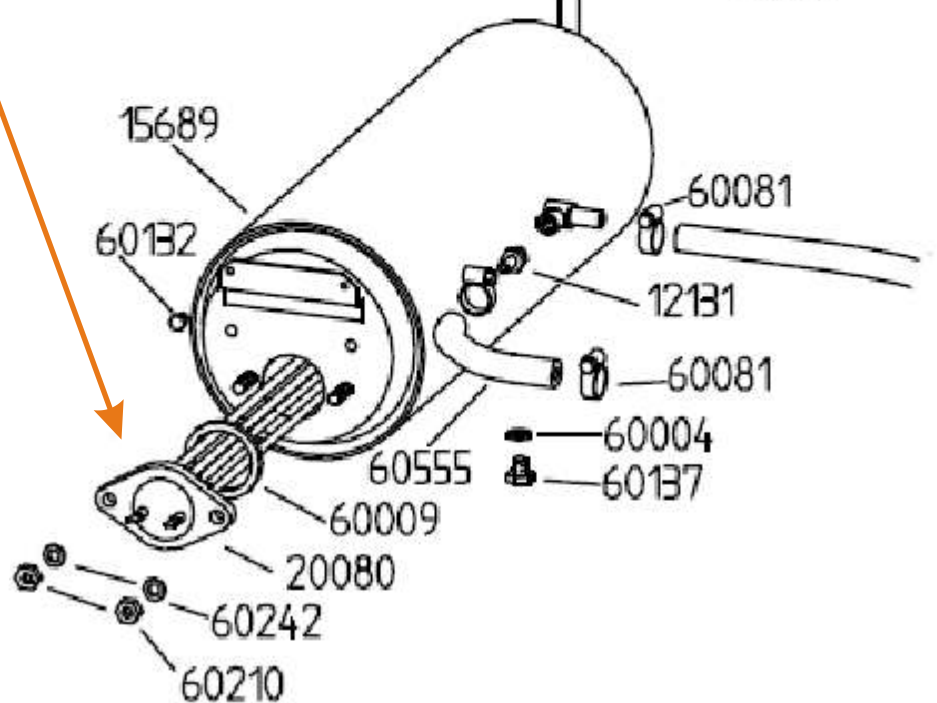
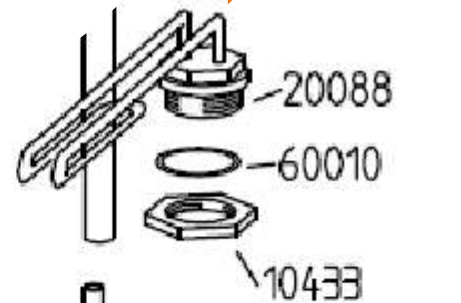

ELECTRICAL SEQUENCE

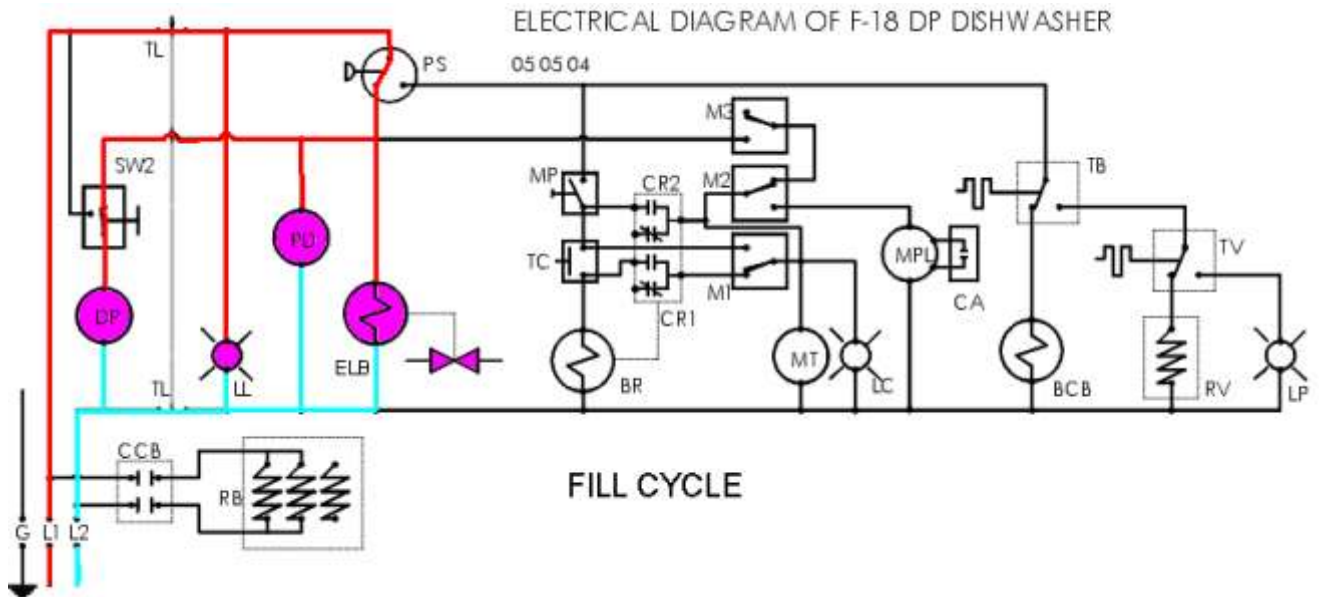

As the unit is powered by the Power Switch (1), it energizes LL(2).
 The Pressure-switch PS energizes the solenoid valve ELB (to fill the wash tank), the detergent pump PD and the drain pump DP.

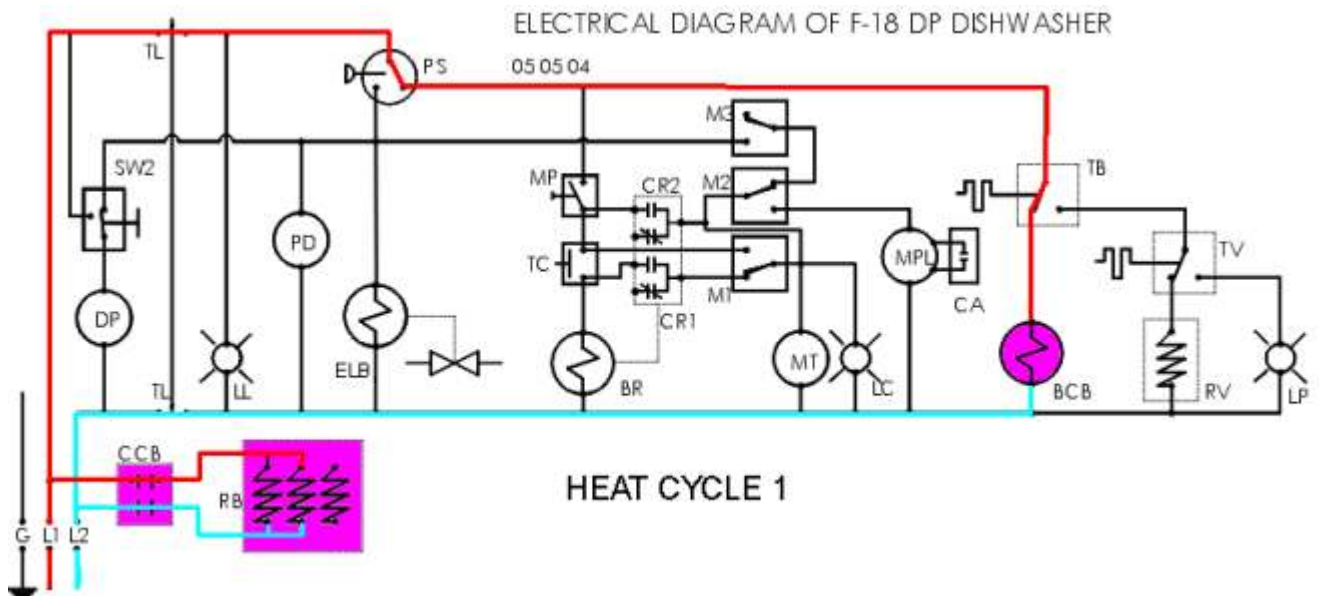

When the pressure-switch PS(20058) is satisfied, it energizes the Booster relay contactor BCB(20104) by the rinse thermostat TB(20596).

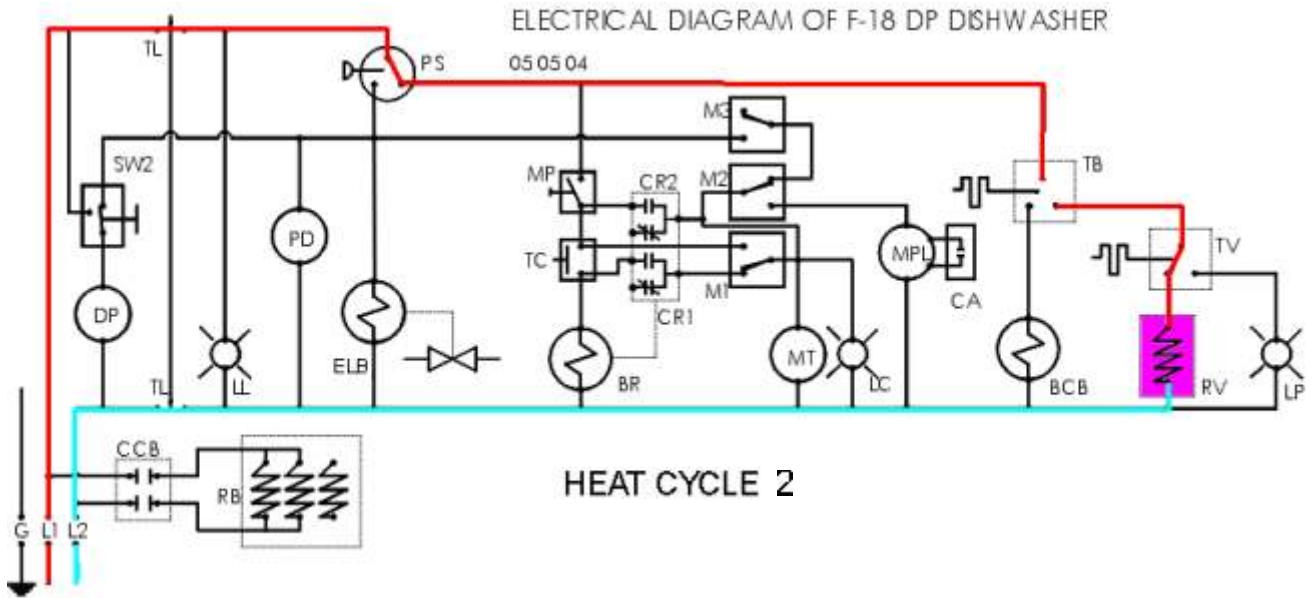

When the Booster thermostat TB is satisfied, it energizes the wash tank heater element RV by the wash thermostat TV.

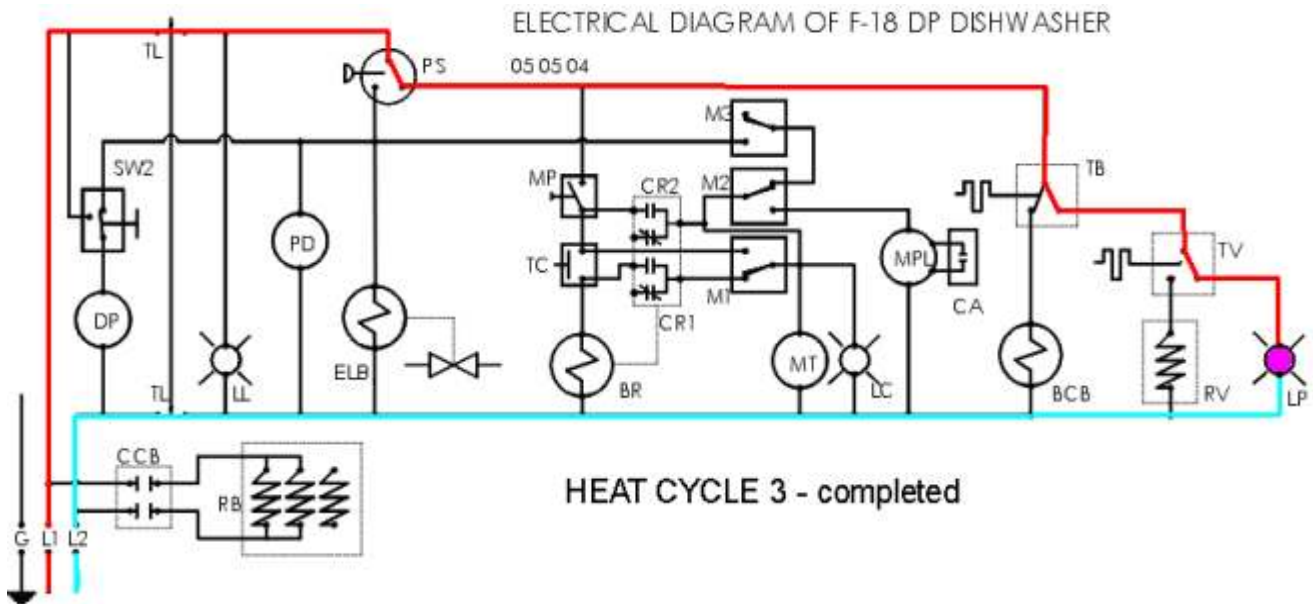

When the thermostat in the wash tank is satisfied, it energizes the indicator light LP.

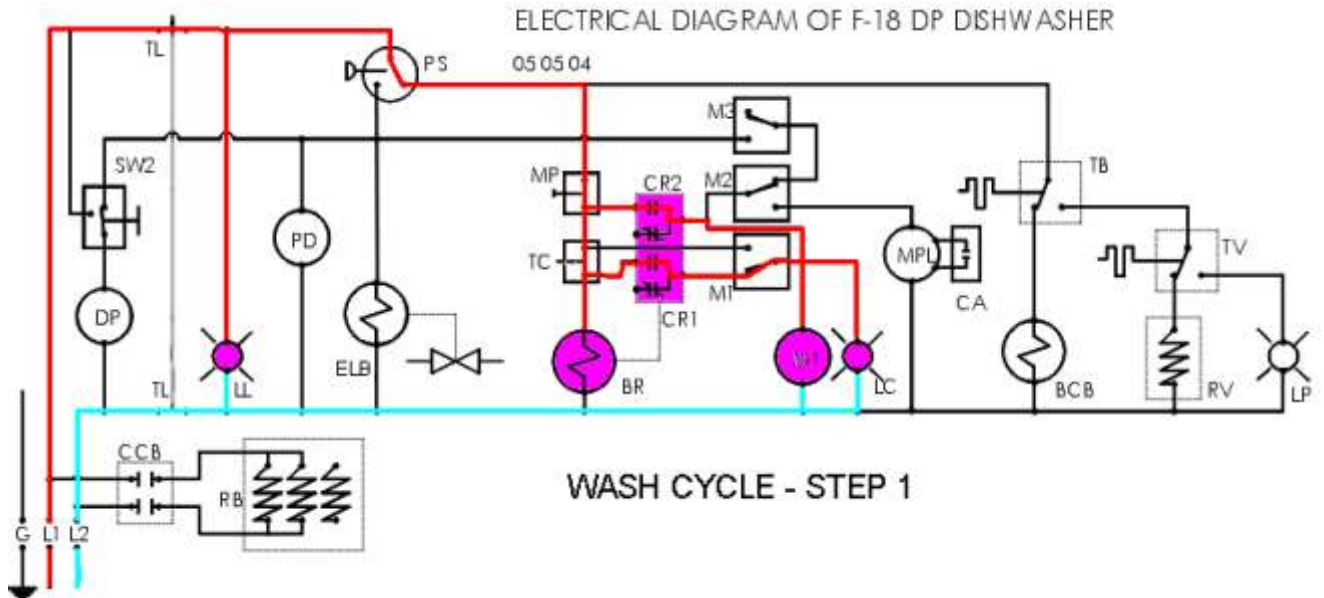

When the Start Cycle TC (6-20519) button is depressed. The small contactor relay (20067) is energized and closes contacts CR1 and CR2. This has two purposes. The first one is to energize both the timer motor and the indicator light LC (7). The second purpose is for CR2 to bypass the Start Switch TC.

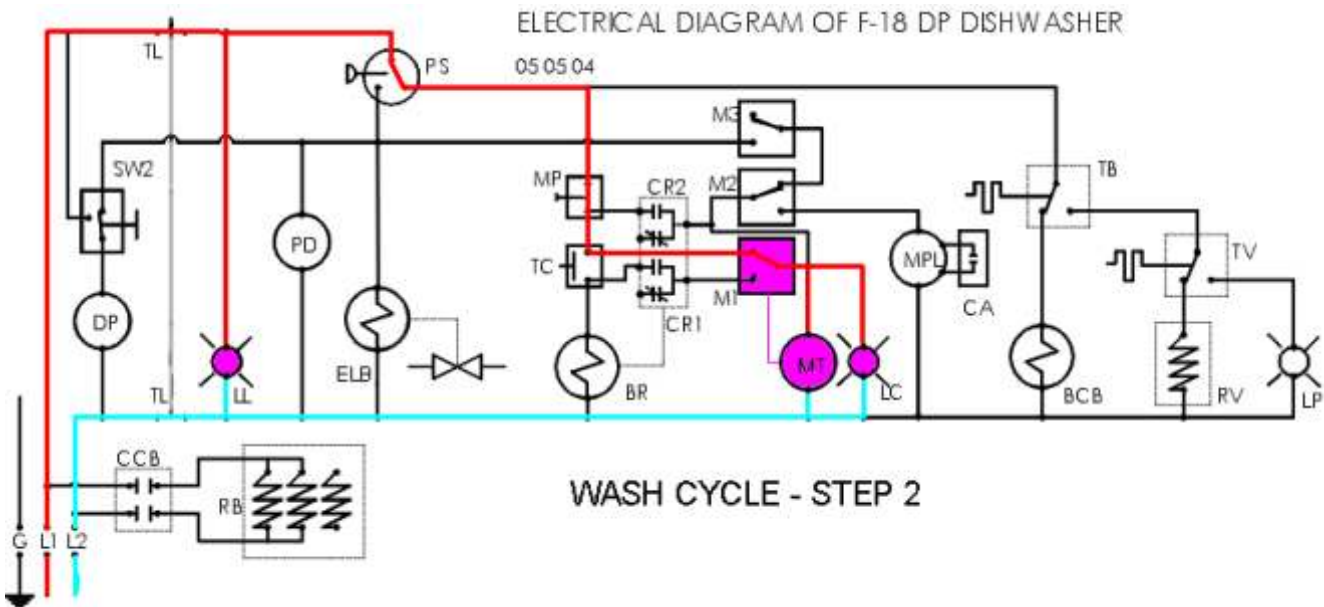

The timer motor MT is energized and starts to turn and closes the first contact M1 which will bypass the small relay contactor and keep the timer motor running during the entire cycle.

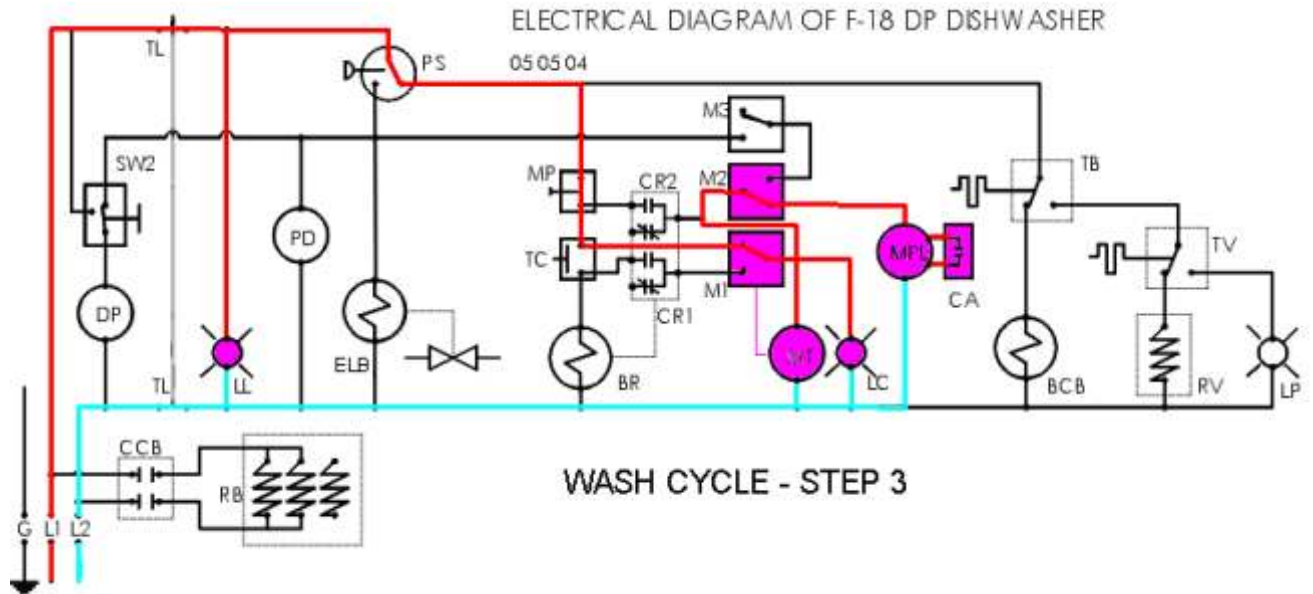

As the timer cam continues to turn, the second switch M2 is closed and energizes the wash pump motor MPL(40240).

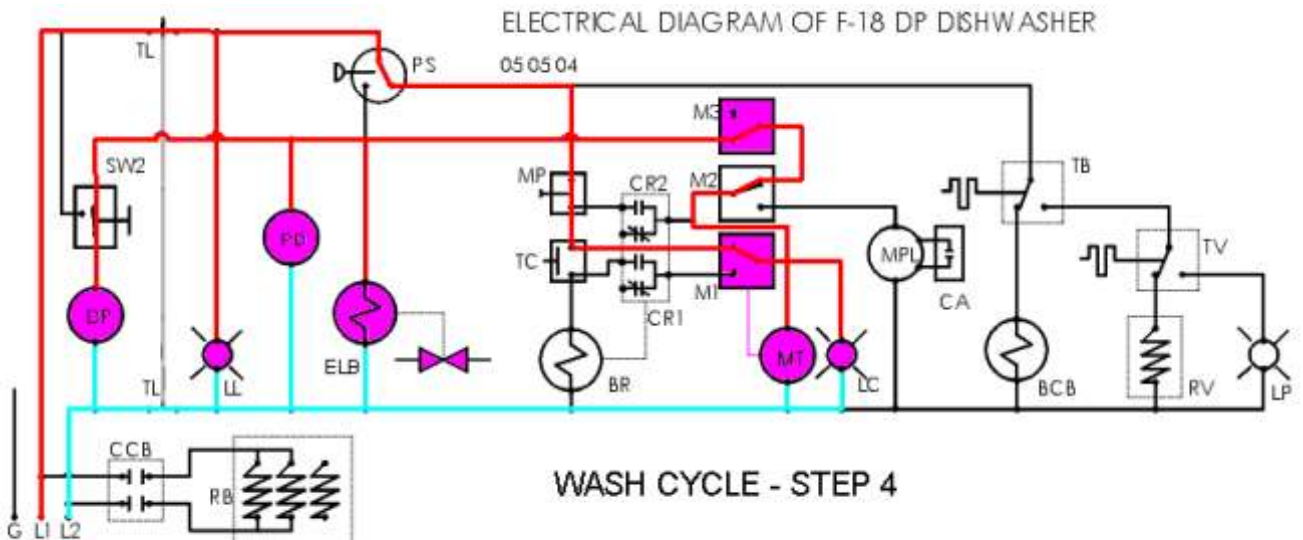

After 150 seconds approximately, switch M2 opens and switch M3 closes to energize the solenoid valve ELB (for rinsing), the drain pump DP and the detergent pump PD. This last about 20 seconds and the circuit reverts back to timer at rest..

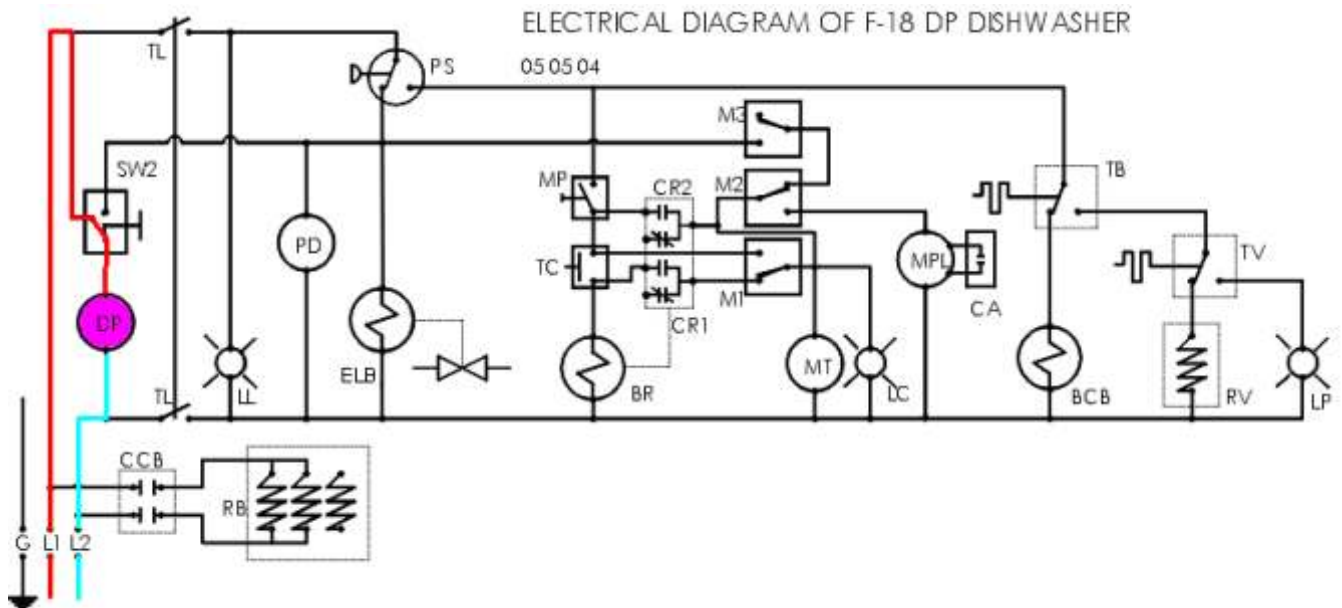

The drain button Sw2 is depressed, power is sent directly to the drain pump DP. The button must be held in place. If the power switch TL is not switched off, the unit will try to fill again when the water level reach about 2 inches.

CHEMICALS AND PUMP ADJUSTMENT

Dishwashers require the use of a detergent and possibly a rinse additive. The detergent must be of commercial strength to work in the unit's short cycle. The rinse additive will help the water to sheet on the glasses and plates, acting as a drying agent.

The products are a Sodium Hydroxide for the detergent and a surfactant isopropanol for the rinse. Quantities will vary with water quality but as a guideline there should be 200 ppm for the detergent and 50 ppm for the rinse-agent. Those products are available from any chemical company. Never use chlorinated product such as sanitizer and bleach. These products can damage the equipment.

Should you run out of these products, you can use residential brand product as a temporary measure. Do NOT use soap that produces suds. Use those product that are sold for dishwashers. Good quality chemical product will improve the washing.

Models 727, 737, F-16, F-16DP, F-18, F-18DP & F-20 are supplied with a factory installed liquid detergent pump to automatically dispense detergent into the wash tank chambers. Before accessing the bottom section of the dishwasher, make sure that the power was turned off at the source (breaker panel).

The bottom panel can only be remove with a flat tool like a screw-driver. Insert the screw-driver in the gap between the front panel and the side panel. Pry open towards you. Do this on both side.



The clear hoses connected to the pumps must be pulled out and fed through the bottom of the dishwasher. The containers can be either to the right or left of the dishwasher. Perforating the stainless panel is not recommended.

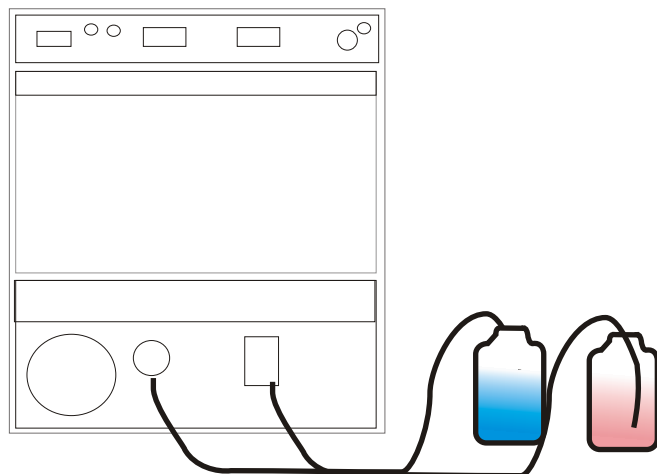
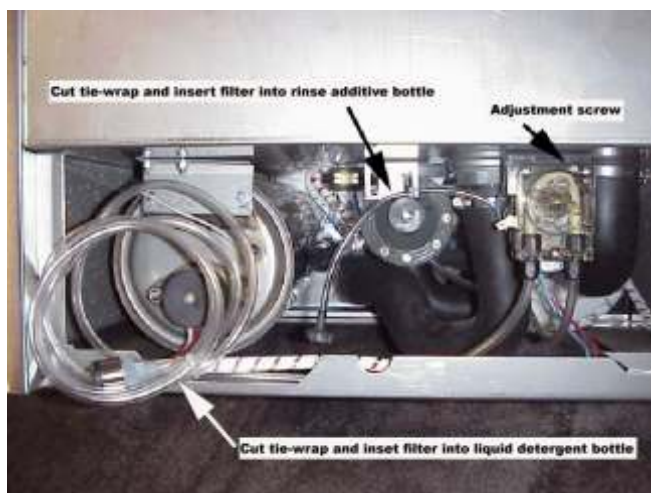



The quantity of liquid detergent can be increased (clockwise) or decreased (counter clockwise) by adjusting the screw on the peristaltic pump. The pump works during the fill cycle and rinse cycle.

(Identified above as "Adjustment screw")

Don't forget to put the panel back on when finished.

RINSE PUMP ADJUSTMENT AND PRIMING

· The rinse pump is standard equipment on all **JET-TECH** machines and automatically injects rinse additive into the rinse water for the final rinse.



· The rinse pump is located in the base of the machine near the booster tank. The front, lower panel (below the door) snaps off to access the rinse pump. Cut the cable tie, route the tube out from the base of the machine and drop the clear vinyl hose and filter into your rinse additive container. (Some models are supplied with a rinse additive bottle that fits inside the base of the machine)



Adjustments should be made clockwise to reduce the amount of rinse additive and counter clockwise to increase the amount of rinse additive.

· If air gets in the rinse hose or if the pump stops drawing additive from the container, the pump may need to be primed.

To Prime (accelerate the injection of chemical) the pump, follow these steps;

1) Turn OFF the machine, pull the overflow, and drain the wash tank. The wash tank must be empty has priming is done during the fill cycle.

2) Get access to rinse-additive pump (see above instructions) Turn the adjusting screw on the rinse pump approximately 10 turns counter clockwise, allowing maximum travel for the piston. The screw may fall out but this is not a problem. Just remember how many turns you had made when the screw fell out.

3) Turn the machine ON and count to 5, then turn the machine OFF and count to 5, do this several times, until the liquid is drawn up the tube to the rinse pump. Because the pump works when the water solenoid



opens, causing the water pressure to push the internal piston, you should be able to see the liquid travel the length of the tube.

4) Once the liquid has reached the back of the pump, turn the adjusting screw on the rinse pump clockwise all the way in and counter-clockwise 3 full turns.

The rinse-aid pump can pump up to 3cc of rinse-additive (drying agent). The liquid is injected directly in to the booster tank.

DO NOT use sanitizer (chlorinated products, bleach) with this pump. It is not made to pump harsh chlorinated liquid. This will void warranty on the dishwasher.

Know Your Application.

When purchasing the detergent, it is important to specify what you want to wash. Most detergents sold on the market are good for regular soil (Non-greasy food on dishes and cups). Coffee and lipstick stains are usually very difficult to remove and pre-washing may be required. Greasy pans will involve a more specialized product. If an incorrect product is used, grease will accumulate inside the washing cabinet and cover everything.

For any other request on set-up and installation, please contact us at 1 888 275 4538 extension 611...

IMPORTANT

Remember to always use caution and protective gears whenever you are manipulating chemicals. They can burn the skin. Follow supplier's instructions carefully.



SPECIFICATIONS

Peristaltic pumps for dish-washing machines

Electronic regulation time-pause

G82

- max. delivery 0,6 l/h - silicone tube for rinse additive

- max. delivery 0,8 l/h - thermoplastic tube for detergent

G152

- max. delivery 1,5 l/h - thermoplastic tube for detergent

G202

- max. delivery 2,0 l/h - thermoplastic tube for detergent

G252

- max. delivery 2,3 l/h - thermoplastic tube for detergent

230V 50/60Hz (24V by request)

* On request: Silicone tube

1 litre = 35.195 once

.55 ml/sec

Components 20588



20352



60204

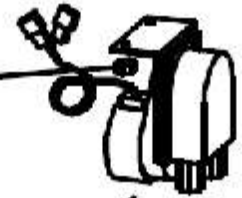

20588

60564

20589



20199

40147



31

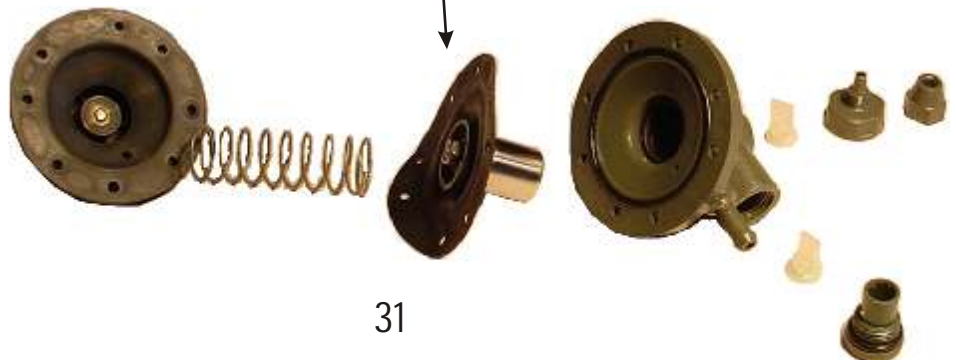

JET-TECH